



City of Rochester

400 Sixth Street
Rochester, MI 48307
P: (248) 733-3700
F: (248) 733-3170
www.rochestermi.org

CITY COUNCIL

REGULAR MEETING AGENDA

Mayor Debbie Jones
Mayor Pro Tem Stuart Bikson
Council Members Jessica Clauser, Christian Hauser,
Sara King, Nancy Salvia and Marilyn Trent

400 Sixth Street	January 26, 2026	7:00 PM
-------------------------	-------------------------	----------------

1. Call to Order
2. Roll Call
3. Pledge of Allegiance
4. Public Comment Scheduled/Non-Scheduled/Presentations
 - A. Recognition of John E. Cieslik's retirement.
 - B. Presentation by Lillian Coronado, senior at Rochester Adams regarding Police Cadet Program.
 - C. Heritage Festival Presentation.
5. Approval of the Consent Agenda
 - A. Receipt of the Check Register Report.
6. Old Business/Tabled Items
7. Public Hearings
8. Legislative Deliberation
 - A. Consideration of a request to set Arbor day, April 22, 2026.
9. Reports and Regular Business
 - A. Annual Tree Report.

- B. Consideration to approve the contract with D.C. Beyers and DLZ Engineering to complete Phase 2 maintenance on the East and West Parking Decks in the amount of \$238,780.
10. Receive a Report from the Various Boards and Commissions
 - A. Receipt of a report from City Beautiful Commission.
 - B. Receipt of a report from the Paint Creek Trailways Commission.
 - C. Receipt of a report from Downtown Development Authority.
 - D. Receipt of a report from Rochester Avon Recreation Authority.
 - E. Receipt of a report from the Rochester Community House Board.
 - F. Receipt of a report from Historical Commission.
 - G. Receipt of a report from Budget & Finance Committee.
 11. Public Comment
 12. General Miscellaneous
 13. Adjourn

NOTE: Anyone planning to attend the meeting who has need of special assistance under the Americans with Disabilities Act (ADA) is asked to contact the City Clerk's Office at 248-733-3700 forty-eight (48) hours prior to the meeting. Staff will be pleased to make the necessary arrangements to provide necessary reasonable accommodations, including auxiliary aids and services, such as signers for the hearing impaired and audiotapes of printed materials being considered at the meeting.



City of Rochester

400 Sixth Street
Rochester, MI 48307
P: (248) 651-9061
F: (248) 651-2624
www.rochestermi.org

MEMORANDUM

Date: January 22, 2026
To: Nik Banda, City Manager
From: Marcy Moriwaki, Deputy Finance Director/Deputy Treasurer
Subject: Greater Rochester Heritage Days Festival, May 30th – May 31st

Issue: Presentation by DDA Director Kristi Trevarrow regarding the newly reimagined Heritage Days Festival.

Analysis: After a one-year hiatus, Heritage Days is returning to the City of Rochester with a refreshed format that blends familiar community favorites with new elements designed to add energy and excitement to the weekend. The goal is to honor the tradition of the festival while introducing new activities that broaden its appeal and enhance the overall experience for residents and visitors.

In addition to longstanding components of Heritage Days, this year's festival will feature several new highlights, including a bike parade, a fishing derby, a hot dog eating contest, and a live band on Saturday night, among other additions. These enhancements are intended to create a more dynamic, two-day experience and encourage participation from a wide range of ages and interests.

We look forward to sharing this exciting update with Council and welcoming Heritage Days back to Rochester Municipal Park.

Requested Motion: Staff respectfully request that Council make a formal motion to approve a budget amendment adding \$4,500 to the previously approved festival budget of \$5,500.

CHECK REGISTER FOR CITY OF ROCHESTER

CHECK DATE 12/29/2025 - 01/02/2026

Check Date	Check	Vendor Name	Amount
Bank A1 ACCOUNTS PAYABLE			
12/30/2025	142291	52-4 DISTRICT COURT	100.00
12/30/2025	142292	AL'S AUTO WASH LLC	87.50
12/30/2025	142293	ANDERSON, ECKSTEIN AND	32,358.40
12/30/2025	142294	ANDERSON, ECKSTEIN AND	4,523.40
12/30/2025	142295	APPLIED INNOVATION	325.90
12/30/2025	142296	BISON PLUMBING	3,000.00
12/30/2025	142297	CECILLA DELATORRE	1,186.79
12/30/2025	142298	CITY OF ROCHESTER-592	2,805.83
12/30/2025	142299	CORELOGIC TAX SERVICE	1,120.28
12/30/2025	142300	CORELOGIC TAX SERVICE	1,654.79
12/30/2025	142301	CORELOGIC TAX SERVICE	1,034.98
12/30/2025	142302	CORELOGIC TAX SERVICE	1,231.97
12/30/2025	142303	DAFOES FEED	1,862.00
12/30/2025	142304	DEBRA JONES	45.00
12/30/2025	142305	DELL MARKETING L.P.	33,095.90
12/30/2025	142306	DETROIT SALT COMPANY	13,021.92
12/30/2025	142307	DTE ENERGY	19,167.30
12/30/2025	142308	GALLS INC.	237.03
12/30/2025	142309	GOODYEAR AUTO SERVICE CENTER	161.50
12/30/2025	142310	GREAT AMERICA FINANCIAL SVCS	462.34
12/30/2025	142311	Housing Market Solutions LLC	1,500.00
12/30/2025	142312	JEFF FIRMAN	245.92
12/30/2025	142313	KAESER AND BLAIR INCORPORATED	1,697.81
12/30/2025	142314	MARILYN TRENT	70.00
12/30/2025	142315	MICHIGAN MUNICIPAL LEAGUE	18.89
12/30/2025	142316	NICHOLAS FRITSCH	27.45
12/30/2025	142317	PRIORITY WASTE	80,964.41
12/30/2025	142318	PSX	989.00
12/30/2025	142319	RAPP'S CONCRETE	1,500.00
12/30/2025	142320	REZ-COMM, INC	2,500.00
12/30/2025	142321	SCHULTZ AND YOUNG PC	2,465.00
12/30/2025	142322	SHERWIN WILLIAMS	42.95
12/30/2025	142323	SPENCER OIL COMPANY	9,856.06
01/02/2026	1341(A)	DLZ MICHIGAN INC	3,969.50
01/02/2026	1342(A)	NYE UNIFORM	1,970.50
A1 TOTALS:			
Total of 35 Checks:			225,300.32
Less 0 Void Checks:			0.00
Total of 35 Disbursements:			<u>225,300.32</u>

CHECK REGISTER FOR CITY OF ROCHESTER

CHECK DATE 01/08/2026 - 01/12/2026

Check Date	Check	Vendor Name	Amount
Bank A1 ACCOUNTS PAYABLE			
01/08/2026	1350(E)	MERS	97,541.77
01/08/2026	142324	ABSOPURE WATER COMPANY	96.90
01/08/2026	142325	AMERIGAS PROPANE LP	1,690.95
01/08/2026	142326	ANDERSON, ECKSTEIN AND	903.50
01/08/2026	142327	APPLIED INNOVATION	120.17
01/08/2026	142328	BADGER METER INC.	236.30
01/08/2026	142329	BRIAN CLAYCOMB	784.50
01/08/2026	142330	CHARTER TOWNSHIP OF SHELBY	70,364.37
01/08/2026	142331	CTS COMPANIES INC	2,536.87
01/08/2026	142332	CULLIGAN OF ROMEO	254.00
01/08/2026	142333	CULLIGAN OF ROMEO	117.00
01/08/2026	142334	CULLIGAN OF ROMEO	85.00
01/08/2026	142335	CULLIGAN OF ROMEO	43.00
01/08/2026	142336	DAFOES FEED	3,258.50
01/08/2026	142337	DAVEY TREE EXPERT COMPANY	2,550.00
01/08/2026	142338	ELEMENT 22 COMMERCIAL GROUP	4,412.43
01/08/2026	142339	ETNA SUPPLY COMPANY	1,880.00
01/08/2026	142340	EVERON	84.63
01/08/2026	142341	GENESSEE VALLEY VAULT	762.00
01/08/2026	142342	GLOBAL SOLUTIONS GROUP, INC	6,779.55
01/08/2026	142343	GOVERNMENT FINANCE	590.00
01/08/2026	142344	GREAT LAKES WATER AUTHORITY	4,293.45
01/08/2026	142345	HEALTHSOURCE SOLUTIONS, LLC	922.00
01/08/2026	142346	I/Q LIFE SAFETY SYSTEMS, INC	1,560.00
01/08/2026	142347	INTERGOVERNMENTAL CABLE COMM-	1,860.00
01/08/2026	142348	MESSINA TRUCKING INC.	1,362.40
01/08/2026	142349	MICHIGAN BUSINESS CONNECTION,	15,143.31
01/08/2026	142350	NICHOLAS BANDA	850.00
01/08/2026	142351	O'REILLY AUTO PARTS	169.88
01/08/2026	142352	OAKLAND COUNTY TREASURERS	46,043.12
01/08/2026	142353	PREMIER TRUCK SALES & RENTALS	1,227.29
01/08/2026	142354	PRIORITY WASTE	2,214.20
01/08/2026	142355	ROCHESTER HILLS PUBLIC LIBRAR	209,672.50
01/08/2026	142356	SOCRRA	240.00
01/08/2026	142357	SPENCER OIL COMPANY	5,723.95
01/08/2026	142358	STONY CREEK RIDGE NORTH	952.00
01/08/2026	142359	SUPERIOR LOCK & KEY, LLC	360.00
01/08/2026	142360	TELUS COMMUNICATIONS (U.S.) I	113.28
01/08/2026	142361	ULLIANCE INC	750.00
01/08/2026	142362	ULYSSES HERNANDEZ	500.00
01/08/2026	142363	VAN HORN TRUCK PARTS INC.	378.67
01/08/2026	142364	WEINGARTZ SUPPLY CO.	1,473.71
01/08/2026	142365	WOLVERINE FREIGHTLINER-	716.25
01/12/2026	1343(A)	BOND ELECTRIC, LLC	868.20
01/12/2026	1344(A)	HYDROCORP	5,780.00
01/12/2026	1345(A)	JODY ALLEN KINJORSKI	1,195.50
01/12/2026	1346(A)	LINEAR CONSULTING FIRM LLC	3,900.00
01/12/2026	1347(A)	PITNEY BOWES BANK INC	964.81
01/12/2026	1348(A)	SUN LIFE FINANCIAL	15,260.43
01/12/2026	1349(A)	WINDCAVE INC	1,280.00
A1 TOTALS:			
Total of 50 Checks:			520,866.39
Less 0 Void Checks:			0.00
Total of 50 Disbursements:			<u>520,866.39</u>



City of Rochester

400 Sixth Street
Rochester, MI 48307
P: (248) 651-9061
F: (248) 651-2624
www.rochestermi.org

RESOLUTION

Arbor Day in Rochester Michigan is April 22, 2026

WHEREAS, in 1872, J. Sterling Morton proposed to the Nebraska Board of Agriculture that a special day be set aside for the planting of trees, and

WHEREAS, the holiday, called Arbor Day, was first observed with the planting of more than a million trees in Nebraska, and

WHEREAS, Arbor Day is now observed throughout the nation and the world, and

WHEREAS, trees can reduce the erosion of our precious topsoil by wind and water, cut heating and cooling costs, moderate the temperature, clean the air, produce life-giving oxygen, and provide habitat for wildlife, and

WHEREAS, trees are a renewable resource giving us paper, wood for our homes, fuel for our fires and countless other wood products, and

WHEREAS, trees in our city increase property values, enhance economic vitality of business areas, and beautify our community, and

WHEREAS, trees, wherever planted, are a source of joy and spiritual renewal,

WHEREAS, Rochester has been a Tree City USA for 13 consecutive years and commits to continue the programs and outreach need to remain in good standing with the Arbor Day Foundation.

WHEREAS, Rochester is committed to working with both our youth within our School system as well as our local residents and environmentalists, to educate them as to the value of the Urban Canopy both on a personal/healthwise and economic/property value basis.

Whereas, the Rochester City Council established in 2020 a Tree Committee made up of three council members and two residents, whose main focus is on communicating the City's desire to continue to not only protect the existing tree canopy, but to increase it with a thoughtful tree planting, education and preservation plan for all residents.



City of Rochester

400 Sixth Street
Rochester, MI 48307
P: (248) 651-9061
F: (248) 651-2624
www.rochestermi.org

NOW THEREFORE BE IT RESOLVED, the Rochester City Council declares Wednesday, April 22, 2026, Arbor Day in the City of Rochester and urge all citizens to celebrate Arbor Day and to support efforts to protect our trees and woodlands, and

FURTHER, they urge all citizens to plant trees to gladden the heart and promote the well-being of this and future generations.

CERTIFICATION

I, Lee Ann O'Connor, being the duly appointed and qualified Clerk of the City of Rochester, Oakland County, Michigan, do hereby certify and declare that the foregoing is a true and correct copy of the Resolution, the original of which is on file in my office, adopted by the Rochester City Council at a regular meeting held on January 26, 2026.

Lee Ann O'Connor

Lee Ann O'Connor, City Clerk



City of Rochester

400 Sixth Street
Rochester, MI 48307
P: (248) 651-9061
F: (248) 651-2624
www.rochestermi.org

January 20, 2026

TO: Honorable Mayor and City Council Members

RE: Year End Tree Removal/Replacement Report for 2025

From: Nik Banda, City Manager/City Forester

The following report represents once again the cooperative work done by Staff of the Parks and the Forestry Division, the Streets Division at DPW, the Fire Department, Private Vendors (Davey Tree and Vince Rampolo of Exterior Concepts) and myself.

The 2025 growing season included a wet Spring, a hot dry Summer and streaky rainfall periods, which was about ½ or normal totals. Overall, it was the 11th warmest year on record for our area. This led to a late leaf drop this fall but with the streaks of rain, a good overall growing season.

We continued to remove dead trees on City property as needed (most were replaced), resulting in 10 additional trees being taken out within the Right-of-Ways or in our Parks.

We had a successful Spring and Fall Street Tree planting program which resulted in the installation of 15 new trees throughout the City. We have caught up with all requests for Street trees to be replanted when a tree was removed previously in the Right-of-Way. We often have to wait a full planting season to let the soil cleanse itself from bacteria that may have previously caused the demise of the Tree.

In April, during our 2025 Arbor Day Celebration, we planted a new 3-inch Autumn Blaze Maple as our “Mother Tree” at our soon to be created Micro Forest in Scott Street Park. And on May 3, more than 45 volunteers gathered for the planting and Ribbon Cutting Celebration of our new Micro Forest. It was a collaboration of the City’s Parks Department, DPW Crews, City Beautiful Commission, the Tree Committee and the Rochester Pollinators. We are pleased to report the Forest is now thriving and meeting expectations as it heads into its second year of existence. We have entertained numerous other Communities that have come to visit our project hoping to establish their own Micro Forest in their home Cities!

The Tree Bate Program had 3 homeowners participate in our program once again this summer.

This year, we had 3 illegally removed Tree instances, which resulted in a total fine of \$80,080 (\$2,940, \$1,820 and \$75,320). The large fine was at Rochester Place Apartments, and they negotiated a tree planting replacement plan with the affected neighbors and the City Tree Committee. All plantings will take place in the Spring of 2026 to ensure a full growing season which is best for the new trees.

The balance in the Tree Fund as of the end of 2025 stands at **\$26,732.93**. The funds dollars come from permit fees (this year \$3,140) and violations for illegal removals over the years. After the settlement dollars from the Apartments is finished we anticipate some of that fine will be deposited in the Tree Fund as they will not be able to plant \$75,320 worth of trees on the Neighbors properties. As always, the Tree Committees goal is to keep the fund balance as minimal as possible, instead turning those dollars into the planting of new trees to help us maintain our existing Tree Canopy and grow it over time.

In the calendar year 2025, I issued 85 permits, compared to 2024's total of 113 permits, which this year permitted the removal of 239 trees vs. 249 trees in 2024. The requests resulted in a replacement requirement of 70 trees this year, versus 73 in 2024, from those seeking to remove more than the maximum 3 tree per year allowance. The balance of the removals was granted under the exemption portion of the ordinance, which does not require tree replacement.

We had 18 additional trees planted in various locations around the City, not including the recently planted trees at the new Micro Forest as they were not 2.5 inches in diameter which would qualify them as a eligible replacement tree under our Tree Ordinance.

Our "Sponsor an Existing Tree" program had 4 participants this year who pay \$200 for the right to hang a Butterfly Tree Charm on the tree of their choice in the Municipal Park. The proceeds go to maintain and expand our Butterfly Gardens by the Sundial at the entrance to the Park.

We continue to participate in the program for controlling the Spongy Moth infestation (formerly Gypsy Moths) in town and do an annual evaluation of the egg masses discovered on our baseline Oak Trees. We had a slight uptick in their population this past hot summer and took appropriate treatments actions this past fall as well as next Spring.

We also secured a Tree Bond in the amount of \$154,840 for the Riverfront Apartment Project scheduled to be constructed starting in Spring of 2026. They need to replant that total or again, put any remaining balance into the Tree Fund upon completion of their project.

We once again were certified by the Arbor Day Foundation as a Tree City USA for 2024, making it our 12th straight year! The 2025 Application is pending approval in early 2026 which will make it 13 years!

As always, please feel free to call me if you have questions about the details of this report.



City of Rochester

400 Sixth Street
Rochester, MI 48307
P: (248) 651-9061
F: (248) 651-2624
www.rochestermi.org

MEMORANDUM

Date: January 26th, 2026
To: Mayor Jones and Council Members
From: Nicholas Schaefer, Director of Public Works
Jason Dickinson, Superintendent DPW
Subject: 2025/2026 Parking Deck Platform Bearing Pad Replacement Project

**Budget Impact: FYE 2025/2026 Capital Control Parking Lot Improvement
514-900.000-974.202**

Issue: City owned parking structures both east and west are due for maintenance.

Analysis: The City Staff would like to contract the Bearing Pad replacements Project to D.C. Beyers Co. as the contractor and DLZ as the engineering firm.

This project is phase two of the maintenance program, with D.C. Beyers doing phase one, which included joint caulking and concrete sealing. Phase two project will be the replacements of the platform bearing pads in both the east and west structure.

The goal of these projects is not only to make sure our decks are safe for employees, business owners, and visitors, but also to make sure we continue the maintenance needed. D.C. Beyers is the sole vendor on this project, due to the fact of not affecting work from phase one.

Requested Action: Approval of the contract with D.C. Beyers and DLZ engineering with the amount of \$238,780 for the Bearing Pad replacement project in both the east and west parking structure. We are currently budgeting \$260,000 for this project.

Attachment(s): (1) Proposal Sheet
(2) Examples of a load bearing pads and locations.



D.C. BYERS CO., INC.
14495 E. Eight Mile Rd.
Warren, MI 48089
Ph: (313) 875-0545

Date: 1-7-2026
To: City of Rochester
Attn: Jason
Project: East/West Deck Bearing Pad
Replacement

PROPOSAL

East Parking Platform Bearing Pad Replacement

Scope of work as follows: (Please see drawing for repair areas)

- *Set up shoring at the end of the precast T adjacent to the bearing pad replacement area
- *Shoring towers to be set up under each precast T Stem of the Precast T plank
- *Set up hydraulic jacks to raise the precast T to take the pressure of the pads and ledger beams
- *Once the pressure is off the (2) pads, remove the old bearing pads and replace with new
- *Let the precast T back down onto the new bearing pads
- *Tear down the shoring

The initial mobilization of the scaffolding, rental of the scaffolding, rental of the bobcat with forks, will be in the initial pricing. Every precast T completed after the initial one will only have the labor, materials, etc. in the pricing.

The price to complete the precast T bearing pads at the (8) areas noted on the drawings deemed "High Priority"\$51,530.00

The price to complete the precast T bearing pads at the (29) areas noted on the drawings deemed "Lower Priority"add \$124,700.00

West Parking Deck Bearing Pad Replacement

Scope of work as follows (Please see drawing for repair areas)

- *The scope of work for the West Deck is the same for the East Deck except at the West Deck the work is under level 3, so it will be necessary to also support the load under level 2. (Re-shoring)

The price to complete the precast T bearing pads at the (4) areas noted on the drawings that are deemed "High Priority"\$42,050.00

****I have attached a preliminary sketch from Solid Platforms, Inc. The City of Rochester will need to have an engineer review the sketch and loads and finalize and "stamp" the exact shoring design to be used. The city should figure an allowance of \$5,000.00 to get that done. This pricing is not included in the proposal above.**

Respectfully submitted, D.C. Byers Company., Inc.

By: 
Thomas Stackpoole, Vice President









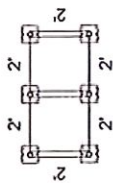

PLAN VIEW
1/4" = 1'-0"

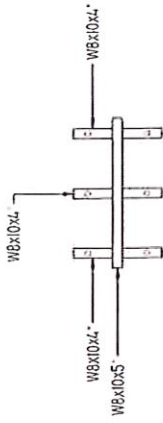

BEAM PLAN
1/4" = 1'-0"

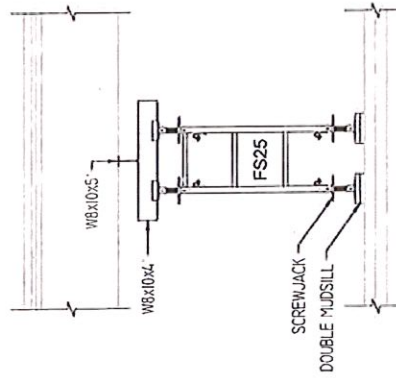

END VIEW
1/4" = 1'-0"

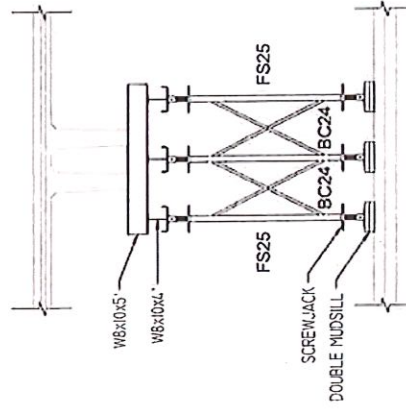

SIDE VIEW
1/4" = 1'-0"

DATE: 1/22/2025	CONTRACTOR: ...
PROJECT: East & West Parking Platforms - Shoring	
LOCATION: East & West Parking Platforms Rochester, Michigan	
SCALE: As Noted	SHEET 1 of 1



Rochester West Deck- Underside Level 2

- High Priority Repairs
- Lower Priority Repairs

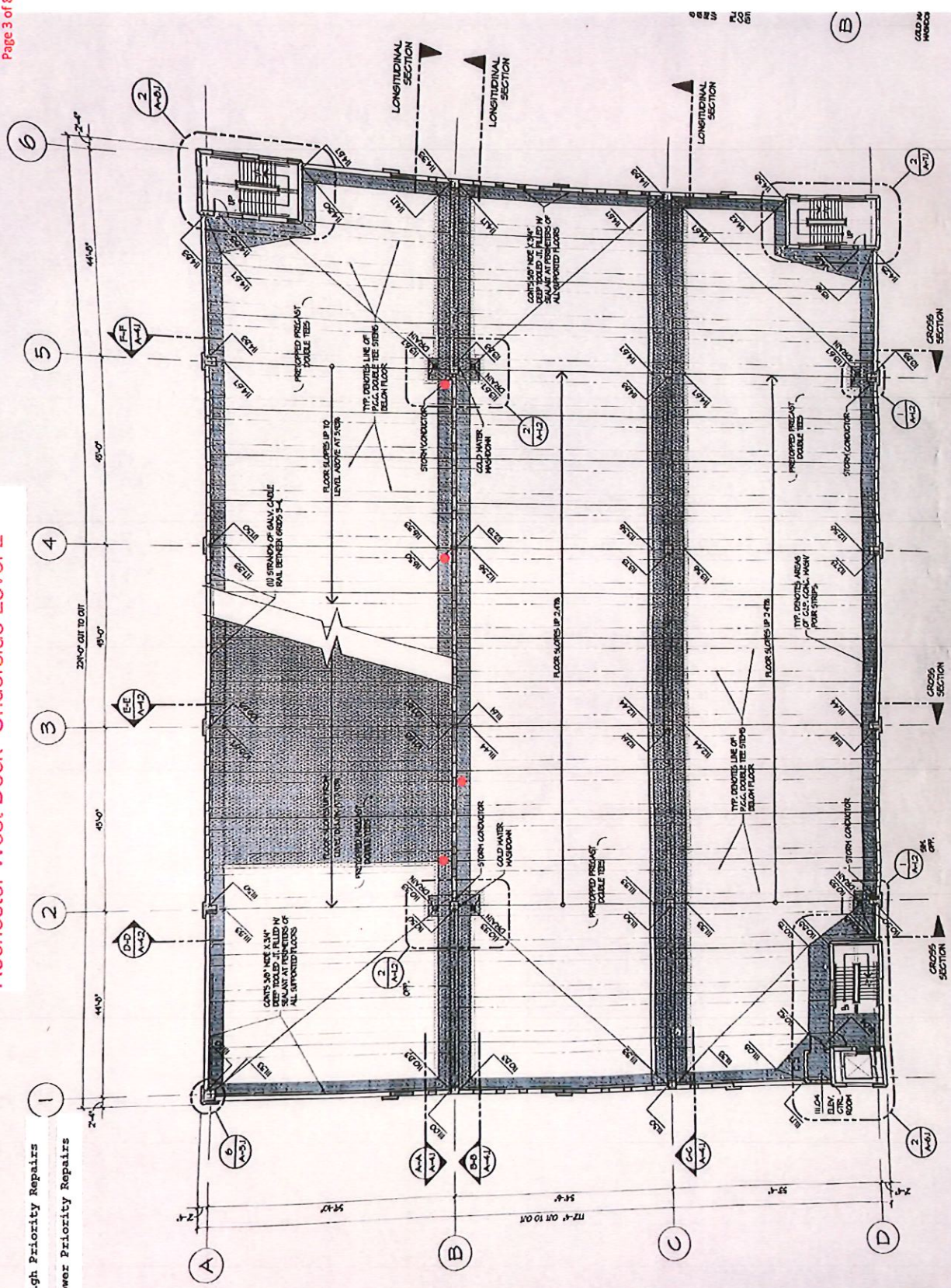

Rochester East Deck

● High Priority Repairs

● Lower Priority Repairs

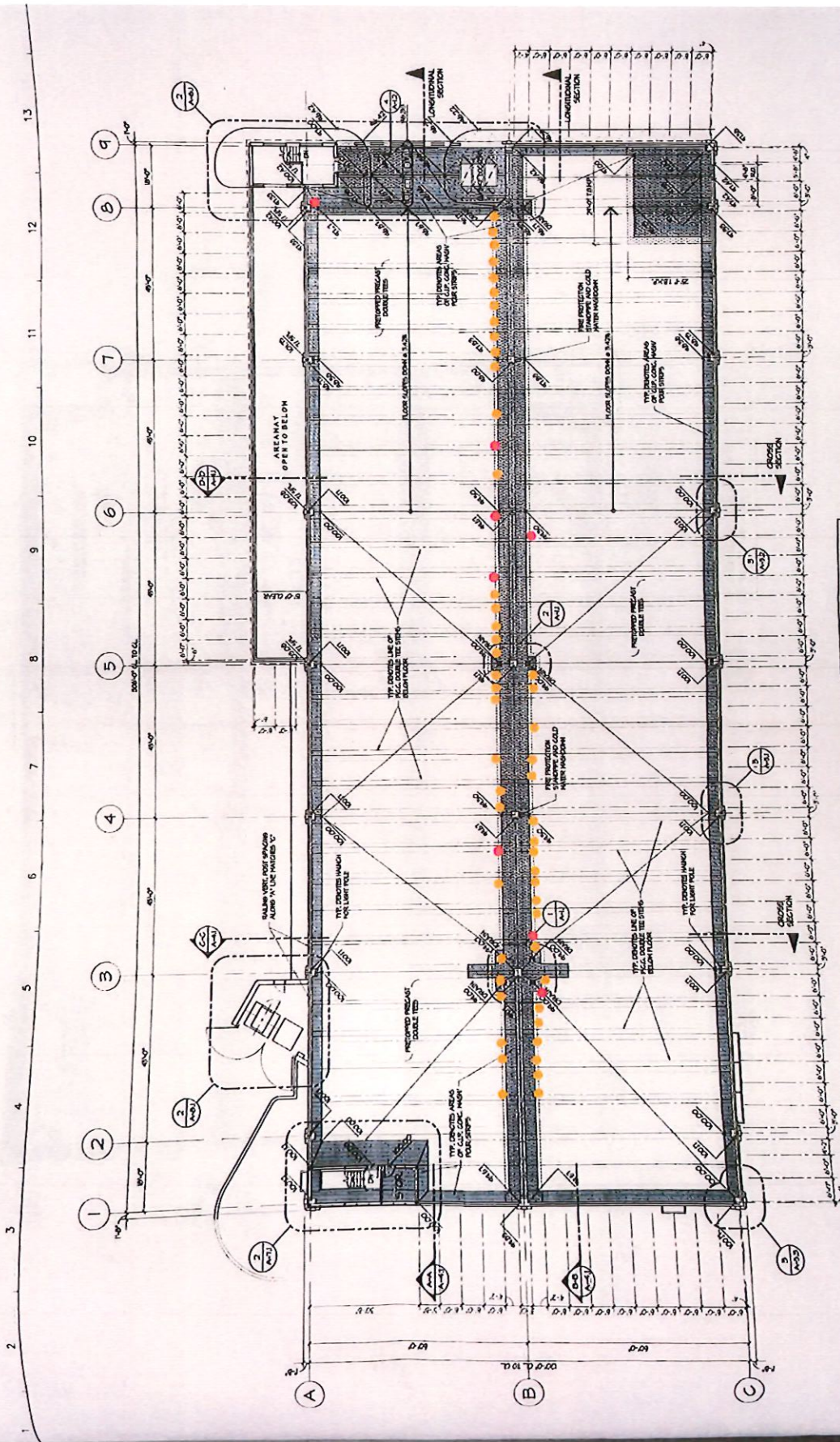

GRADE CONVERSION
100.00 DRAWING BASE = EL. 756.00
PER SITE PLAN DATA



UPPER LEVEL FLOOR PLAN
SCALE: 1/8" = 1'-0"



INNOVATIVE IDEAS
EXCEPTIONAL DESIGN
UNMATCHED CLIENT SERVICE

WORK ORDER PROPOSAL

Date	March 7, 2025	Client PO #	
Client Name	City of Rochester Jason Dickinson	Work Site Name	East and West Parking Garage
Title		Address	
Address	400 Sixth St	City	Rochester
City	Rochester	State	Michigan
State	Michigan, 48307	Telephone	
Telephone		Fax	
Fax		Other Notes	
E-mail	JDickinson@rochestermi.org	DLZ Account #	WF25002350
Est. Start Date	7/1/2025 (TBD)		
Est. End Date	10/31/2025 (TBD)		

GENERAL

Scope of Structural Engineering and Construction Observation Services	Fee	Fee Type
DLZ Michigan, Inc. (DLZ) understands that the City of Rochester, Michigan (CLIENT) is requesting structural engineering services to assist with the shoring of the existing East and West Parking Garage floor structure for bearing pad replacement (See Exhibit C).		
Under this work order DLZ shall provide the following under the Lump Sum scope of work: <ul style="list-style-type: none"> Develop structural loading criteria and a general shoring layout drawing for each parking garage to facilitate the replacement of the bearing pads. Structural loading criteria and general layout drawing will be signed and sealed by a design professional registered in the State of Michigan. Review the City's Contractor provided shoring tower shop drawings. The Contractor's shop drawings are to be based on the loading criteria developed by DLZ. DLZ will return the shop drawings stamped with DLZ's standard shop drawing stamp.	\$9,500.00	Lump Sum
Due to unknowns of contractor scheduling and work, DLZ shall provide the following scope of work on an Hourly Rate, Not to Exceed basis: <ul style="list-style-type: none"> Periodic construction observation to review if the installation of the shoring towers is in conformance with the contractor's shop drawings. For the purpose of this proposal, it is assumed up to twenty (20) site visits may be made. Field observation reports for each site visit during construction. 	\$11,000.00	Hourly NTE

4494 Elizabeth Lake Rd, Waterford Township, MI 48328 | OFFICE 248.681.7800 | ONLINE WWW.DLZ.COM

Akron Bellefontaine Bridgeville Burns Harbor Chicago Cincinnati Cleveland Columbus Detroit Fort Wayne Grand Rapids Green Cove Springs
Indianapolis Jacksonville Joliet Kalamazoo Knoxville Lansing Lexington Logan Madison Melvindale Merrillville Munster Muskegon Port
Huron Saint Joseph San José South Bend Toledo Waterford Whiting



INNOVATIVE IDEAS
EXCEPTIONAL DESIGN
UNMATCHED CLIENT SERVICE

City of Rochester
Parking Garage Bearing Replacement Shoring
Page 2 of 2

Work considered to be outside the scope of this Work Order includes but is not limited to:

- Preparation specifications or bidding documents
- Material testing
- Inspection of the existing Parking Garages.
- Other work not specifically stated in the above scope of work

Service to be Provided by the CLIENT:

- Coordination with the Contractor
- Contractors shoring tower shop drawings

Compensation for services rendered

	Total Fee	\$20,500.00
--	------------------	--------------------

PROFESSIONAL SERVICES FEE

For performing the above professional services, DLZ will be paid on as described above. Payment will be made monthly in proportion to services performed upon presentation of proper invoices, claims and vouchers. DLZ reserves the right to assess a service charge of 1.5% per month for any outstanding balance exceeding 30 days from the invoice date.

The Standard Terms and Conditions, as set forth as attached Exhibit A, are incorporated here into and made a part of this Work Order Proposal. The Client referred to in the Standard Terms and Conditions means The City of Rochester.

If you approve and accept this proposal, please sign, date and return one copy of this work order for our records. Should you prefer to issue a Purchase Order as your official acceptance, we request that you reference this proposal in your paperwork.

Very truly yours,
DLZ

Manoj Sethi, P.E.
President

Approved and Accepted

Signature _____
Printed Name _____
Title _____
Date _____

Attachments:

- Exhibit A –DLZ Terms and Conditions
- Exhibit B – Standard Hourly Rate Schedule
- Exhibit C – DC Byers Proposal
- Copy: LG, ML, CVAN, File

x:\crm\opportunities\2024\south bend\architectural\{sb24014642} indyne - andrews afb misc fdns\working proposal\indyne andrews work order.docx

EXHIBIT A

DLZ'S STANDARD TERMS AND CONDITIONS

- 1. INVOICES AND PAYMENT:** Unless the parties have agreed otherwise, DLZ will submit monthly invoices to CLIENT for services performed in the prior month. Except to the extent CLIENT disputes in good faith all or a portion of a DLZ invoice, CLIENT will pay DLZ the invoiced amount within thirty (30) days from the date of the invoice; and, in default of such payment, agrees to pay all cost of collection, including reasonable attorney's fees, regardless of whether legal action is initiated. Invoiced amounts not in dispute will accrue interest at one percent (1%) per month after they have been outstanding for over thirty (30) days. If an invoiced amount not in dispute remains unpaid sixty (60) days after the date of the invoice, DLZ may, upon giving seven (7) days written notice of its intent to do so, suspend all project services until all unpaid invoiced amounts not in dispute are paid in full. If an invoice remains unpaid ninety (90) days after the date of the invoice, DLZ may, upon giving seven (7) days written notice of its intent to do so, declare CLIENT to be in breach of this agreement.
- 2. CONSTRUCTION SERVICES:** If DLZ's scope of services includes providing professional services during the project's construction phase, DLZ will not have control over or be responsible for contractor means, methods, techniques, sequences, procedures, or schedule, or the contractor's failure to comply with the construction contract documents or applicable laws, ordinances, rules or regulations. If DLZ provides construction inspection or observation services, DLZ will report to CLIENT all contractor deviations from the construction contract documents that come to DLZ's attention. However, such services are solely intended to enable DLZ to maintain familiarity with, and keep CLIENT informed of, the general progress and quality of the contractor's work, and not to require DLZ to perform exhaustive inspections of contractor work for its compliance with the construction contract documents, which shall remain solely contractor's responsibility.
- 3. CHANGES IN REQUIREMENTS:** In the event additional services are required due to a change, after the date of this agreement, in CLIENT's requirements, or in the applicable law, standards, or governmental requirements or policies, DLZ will be entitled to additional compensation for such additional services.
- 4. SURVEY STAKING:** If DLZ's scope of services includes survey layout, DLZ will not be responsible for subsequent disturbances of its layout except to the extent caused by DLZ or persons for whom it is responsible.
- 5. MISCELLANEOUS EXPENSES:** Except to the extent otherwise provided in this agreement, CLIENT is responsible for all third-party fees and charges including, without limitation, fees and charges for inspections, zoning or annexation applications, assessments, soils engineering, soils testing, aerial topography, permits, rights-of-entry, bond premiums, title company charges, blueprint and reproduction costs, and all other third-party fees and charges.
- 6. CHANGE OF SCOPE:** DLZ's scope of services in this agreement is based on facts known at the time of execution of this agreement, including, if applicable, information supplied by CLIENT. DLZ will promptly notify CLIENT in writing of any perceived changes to its scope of services required by new information or by persons or circumstances beyond DLZ's control, and the parties shall negotiate modifications to this agreement before DLZ begins performance of the revised scope.
- 7. SAFETY:** DLZ will take reasonable steps to protect the safety of its employees, and to perform its services in a safe manner. DLZ is not responsible for project safety other than with regard to its own services.
- 8. REUSE OF PROJECT DELIVERABLES:** CLIENT's use of any project documents or DLZ deliverables, including electronic media, for any purpose other than that for which such documents or deliverables were originally prepared, or alteration of such documents or deliverables without written verification or adaption by DLZ for the specific purpose intended, will be at CLIENT's sole risk.
- 9. OPINIONS OF CONSTRUCTION COST:** Any opinion of construction costs prepared by DLZ is supplied for the general guidance of the CLIENT only. Since DLZ has no control over competitive bidding or market conditions, DLZ cannot guarantee the accuracy of such opinions as compared to contractor bids or actual cost to CLIENT.
- 10. INSURANCE:** During the performance of its services and for two years thereafter, DLZ will maintain the following minimum insurance coverage: General Liability- \$1,000,000 per occurrence, \$2,000,000 general aggregate, \$2,000,000 products/completed operations aggregate, \$1,000,000 personal/advertising injury aggregate; Automobile Liability- \$1,000,000 combined single limit; Workers Compensation and Employers Liability- in conformance with statutory requirements, and \$1,000,000 employers liability; and Professional Liability- \$2,000,000 per claim and in the aggregate. Certificates evidencing such coverage will be provided to CLIENT upon request. If DLZ is providing construction phase services, CLIENT agrees to require its contractor to include DLZ as an additional insured on the contractor's General Liability and Automobile Liability insurance policies, and DLZ's above-listed coverage will be excess over the contractor's coverage, which will be primary.
- 11. INDEMNITY:** To the fullest extent permitted by law, each of the parties agrees to indemnify and save harmless the other party from and against all liability, damages, and expenses, including reasonable attorney's fees, sustained by the other party by reason of injury or death to persons or damage to tangible property, to the proportionate extent caused by the negligent acts or omissions of the indemnifying party or its employees.
- 12. CONSEQUENTIAL DAMAGES:** Neither party will be liable to the other for consequential, special, incidental, indirect, liquidated, or punitive damages.
- 13. LIABILITY:** No employee of DLZ or of its parent, subsidiary, or affiliated companies will be personally liable to CLIENT. DLZ's total liability to CLIENT, and any coverage of CLIENT as an additional insured under any of DLZ's insurance policies, for injuries, claims, losses, expenses or damages arising out of DLZ's services or this agreement from any causes including, but not limited to, DLZ's negligence, error, omissions, strict liability, or breach of contract, will not exceed the total compensation received by DLZ under this agreement.
- 14. DISPUTES:** Any claim or controversy arising out of or relevant to this agreement, or the breach thereof, shall be settled by binding arbitration in the state in which the project is located, in accordance with the rules of the American Arbitration Association, and judgment upon any award rendered by the arbitrator(s) may be rendered in any court having jurisdiction thereof.
- 15. STATUTE OF LIMITATIONS:** The parties agree that the time period for bringing claims regarding DLZ's Service's under this agreement expires on the earlier of one year after completion of the project, or two years after completion of DLZ's project services.
- 16. DELAYS:** DLZ is not responsible for delays caused by persons or circumstances for which DLZ is not responsible.
- 17. SHOP DRAWINGS:** If DLZ's scope of services includes reviewing shop drawings, such reviews are solely with regard to their general conformance with the design concept, and not for the purpose of reviewing or approving their accuracy, completeness, dimensions, quantities, constructability, compatibility with other construction components, or compliance with the requirements of the construction contract documents, all of which remain the contractor's responsibility. DLZ is not responsible for reviewing or approving the contractor's safety precautions or construction means, methods, sequences or procedures.
- 18. ACCEPTANCE:** Both parties will consider DLZ's initiation of services prior to execution of this agreement in order to accommodate CLIENT, at CLIENT's request, as CLIENT's formal acceptance of all of the terms and conditions in this agreement.
- 19. STANDARD OF CARE:** DLZ will perform its services with the care and skill ordinarily exercised by members of its profession currently practicing under similar conditions in the same locale. DLZ does not make, and expressly disclaims, any other warranties, express or implied, relating to its services including, without limitation, warranties of merchantability and fitness for a particular purpose. DLZ shall be entitled to rely on all CLIENT-provided information except to the extent otherwise stated in the agreement.



City of Rochester

400 Sixth Street
Rochester, MI 48307
P: (248) 651-9061
F: (248) 651-2624
www.rochestermi.org

CITY BEAUTIFUL COMMISSION REGULAR MEETING AGENDA

***Chairperson Jeanine Offer, Vice Chair Laura Murphy, Secretary Sue Butala
Members: Tammy Byers, Julia Johnson, Sandra Montes, Tracy Gottschalk
City Council Liaison: Jessica Clauser
Student Liaisons: Emma Roosevelt***

400 6th Street

January 14, 2026

7:00 pm

- 1) Call to Order
- 2) Roll
- 3) Approval of November meeting minutes
- 4) Pranav - Sound Amplifier Update
- 5) Elections
- 6) Nik & DPW update
- 7) Mission Statement Update to incorporate scope of new projects
- 8) 2025/2026 Goals & Objectives
 - a) Project updates/ideas:
 - i) Raised Bed Sensory Gardens and Picnic Shelters at All-Abilities Park
 - ii) Rain Garden by path to Paint Creek Trail in Park - Spring, up to \$500
(1) Committee of people to head this up
- 9) Ideas for 2026/2027 Budget Request
 - a) Pocket Garden on Walnut: ideas and funding request
 - b) Revamp of former garden area at Scott Street Park: ideas and funding
 - c) Outdoor Fitness Stations, update and ideas
 - d) Additional project ideas
- 10) Good Neighbor Application
- 11) Misc / New Business



4393 Collins Road
Rochester, MI 48306
(248) 651-9260
Paintcreektrail.org

PAINT CREEK TRAILWAYS COMMISSION
REGULAR PUBLIC MEETING NOTICE AND AGENDA

Tuesday, January 20, 2025, 7:00 p.m.
Paint Creek Cider Mill, 4480 Orion Road, Rochester, Michigan 48306

MEETING AGENDA

1. Call to Order
2. Roll Call
3. Pledge of Allegiance to the Flag of the United States of America
4. Amendments to/Approval of January 20, 2026, Agenda
5. Approval of Invoices
6. Approval of Treasurer's Report
7. Approval of Minutes – December 16, 2025, Meeting
8. General Public Comment
9. For Approval: 2024 Audit
10. Presentation: Wag N Wash – Potential Community Partnership with PCTC
11. For Approval: Eastport Village – Escrow Agreement for Legal and Engineering Review Services
12. For Discussion: Events, 2026
13. For Approval: Committee Appointments, 2026
14. Project Report: Bridge 31.7 Replacement
15. Manager's Report

16. Commissioner Reports

17. Adjournment

Next meeting: Tuesday, February 17, 2026, 7:00 p.m.,
Paint Creek Cider Mill



Love local
ROCHESTER 

Rochester Downtown
Development Authority

Downtown Collaboration Studio
431 S. Main Street
Rochester, MI 48307
248.656.0060
DowntownRochesterMI.com

**Regular Meeting Agenda
Wednesday, January 21, 2026 7:00 pm
Rochester Municipal Building, 400 Sixth Street**

1. Call to Order
2. Roll Call
3. Approval of Meeting Minutes – November 12, 2025
4. Audience Comments
5. Liaison Reports
 - A. City Council – Jessica Clauser
 - B. Chamber of Commerce – Bob DiTommaso
 - C. Historical Commission – Don Sienkiewicz
 - D. Principal Shopping District – Paul Haig
6. General Business Items
 - A. New Oakland County Board of Commissioners DDA Policy – Kristi Trevarrow
 - B. Volunteers for Budget Sub-Committee – Ben Giovanelli
7. Goals & Objectives Agenda Items
 - A. The Market + The Graham – Ben Giovanelli
 - B. Social District – Ben Giovanelli/Kristi Trevarrow
 - C. The Big, Bright Light Show – Kristi Trevarrow
 - D. Love Local Art Program – Kristi Trevarrow
 - E. Miscellaneous
8. Receipt of Regular Reports
 - A. Executive Director Update
 - B. Events & Marketing Update
 - C. Financial Report for DDA
 - D. Business Development Committee
 - E. Site Development Committee
9. Adjourn

The next regular meeting of the Rochester DDA will be held on Wednesday, February 18, 2026.



Regular Board Meeting Agenda

Chairman: John Muenk, Vice Chair: Emily Schoeller, Secretary: David Berletich
Board Members: Sara King, Dr. Julie Alspach, Theresa Mungoli, Amanda MacCormick
Student Representatives: Janelle Hayes

500 E. Second Street

January 21, 2026

5:00 PM

1. Call to Order
2. Roll Call
3. Reading and consideration of the minutes:
 - a. [December 17, 2025 Regular Board Meeting Minutes](#)
4. Approval of Agenda
5. Public comment – reserved time (for items listed on this agenda)
6. Communications
 - a. Secretary of the Board
 - b. Members of the Board
7. Financial Reports
 - a. List of Bills – December 2025
 - i. Request for approval of the bills in the amount of: [\\$118,539.09](#)
 - b. Review of the monthly budget reports
 - i. [Revenue Vs Budget](#)
 - ii. [Expense Vs Budget](#)
 - iii. [Trial Balance Report](#)
 - iv. [Budget Summary](#)
8. Administrative Reports
 - a. [Executive Recreation Director's Report](#)
 - b. [Assistant Recreation Director's Report](#)
 - c. [Communications Officer Report](#)
 - d. [Sports Report](#)
 - e. [Camps Report](#)
 - f. [Events Report](#)
 - g. [Activities Report](#)
 - h. [Adaptive Report](#)
 - i. [Rec Center & Facility Reservations Report](#)
9. Unfinished Business



Regular Board Meeting Agenda

Chairman: John Muenk, Vice Chair: Emily Schoeller, Secretary: David Berletich
Board Members: Sara King, Dr. Julie Alspach, Theresa Mungioli, Amanda MacCormick
Student Representatives: Janelle Hayes

500 E. Second Street

January 21, 2026

5:00 PM

- a. None
- 10. New Business
 - a. Meeting Dates 2026 - January 2027
 - b. Election of board positions
 - c. Assigning of board committees
- 11. Miscellaneous
- 12. Public Comments – General
- 13. Adjournment

Sub-Committees:

Human Resources Committee – Matthew McDaniel, Theresa Mungioli, Emily Schoeller
Budget Committee – David Berletich, Steven Siedlarz, Sara King
Policy and Procedures Committee – John Muenk, Matthew McDaniel, Sara King
Strategic Planning Committee – Theresa Mungioli, David Berletich, John Muenk

RCH
Board Meeting Agenda
January 20th. 2026.

Open meeting 4.00pm.

. November meeting minutes.

. YTD financial's.

. Director's report:

- . 1. Update on building renovation.
- . 2. Upcoming public planning commission meeting Feb 2nd.
- . 3. City workshop Jan 24th.
- . 4. Issues on state funding for RCH.
- . 5. New telephone system.
- . 6. Supervisor Lisa new position.

Misc.

Close meeting



City of Rochester

400 Sixth Street
Rochester, MI 48307
P: (248) 733-3700
F: (248) 733-3170
www.rochestermi.org

Rochester Historical Commission Regular Meeting Agenda

Chairperson: William Pietrzyk, Vice Chairman: TBD
Secretary: TBD, Treasurer: Cy Saverino, Archives & Accessions Liaison: Lynn Anderson
Greater Rochester Heritage Days Liaison: Don Sienkiewicz, Rochester Cemetery Commission:
William Pietrzyk, Downtown Development Authority (DDA): Don Sienkiewicz,
RHC Members: Robert Michalka, Patrica Kane, Julia Johnaon, Donald Washeleski..
Rochester City Council Liaison: TBD, Alternate Kay Johnson

400 Sixth Street	January 22, 2026	7:00 pm
-------------------------	-------------------------	----------------

- Call to order
- Approval of RHC meeting minutes for November- All
- Treasurers Report – Cy
 - 2027 Budget Report Ending Date November 30, 2025
- Secretary Report – Communications – Bill/Cy
- Update on Historical Plaque Program – Lynn
- Van Hoosen Museum Update on Archive Project- Julia
- RHC Liaison Reports
 - Archives & Accessions – Julia
 - Founder's Day March 22, 2026– Bill
 - DDA – Don
 - Greater Rochester Hertiage Days May 30-31, 2026 – Don
 - Rochester Cemetery Commission – Bill
 - Number of Sales of DUR Book – Cy
 - America 250 th Project-Mt Avon -Bill
 - Unfinished and New Business
- Miscellaneous
- Adjournment: **Next Meeting February 26, 2026**