



City of Rochester

400 Sixth Street
Rochester, MI 48307
P: (248) 733-3700
F: (248) 733-3170
www.rochestermi.org

CITY COUNCIL

REGULAR MEETING AGENDA

Mayor Nancy Salvia
Mayor Pro Tem Stuart Bikson
Council Members Christian Hauser, Debbie Jones,
Sara King, Steve Sage and Marilyn Trent

400 Sixth Street	May 12, 2025	7:00 PM
-------------------------	---------------------	----------------

1. Call to Order
2. Roll Call
3. Pledge of Allegiance
4. Public Comment Scheduled/Non-Scheduled/Presentations
 - A. Presentation from New Day Foundation.
 - B. Recognition of Dinosaur Hill Volunteers.
 - C. Proclamation recognizing Mental Health Awareness Month.
5. Approval of the Consent Agenda
 - A. Consideration of the minutes from the April 14, 2025 and April 28, 2025 Regular Council Meeting.
 - B. Consideration to approve the Uplifting Music in the Park Event
 - C. Receipt of the Check Register Report.
6. Old Business/Tabled Items
7. Public Hearings
8. Legislative Deliberation
 - A. Consideration of Resolution to Amend Charter to Eliminate City Council Election Primaries.

9. Reports and Regular Business
 - A. Consideration of Termination and Release of Easement - 203 E. University.
 - B. Consideration to award CDBG funds to Mierzwa Inc. for the park path improvement project.
 - C. Consideration of a request to purchase a 2025 Chevrolet Tahoe for Road Patrol for \$53,984.00 using the County Bid pricing.
 - D. Consideration of a resolution to allow the city to participate in the Fire Insurance Withholding Program.
 - E. Mayor nominations to Boards and Commissions.
 - F. City Council nominations for Boards and Commissions.
10. Receive a Report from the Various Boards and Commissions
 - A. Receipt of a report from the Principal Shopping District.
 - B. Receipt of a report from the Planning Commission.
11. Public Comment
12. General Miscellaneous
 - A. Request for Closed Session For City Council to consider Attorney/Client Privileged Opinion Letter.
13. Adjourn

NOTE: Anyone planning to attend the meeting who has need of special assistance under the Americans with Disabilities Act (ADA) is asked to contact the City Clerk's Office at 248-733-3700 forty-eight (48) hours prior to the meeting. Staff will be pleased to make the necessary arrangements to provide necessary reasonable accommodations, including auxiliary aids and services, such as signers for the hearing impaired and audiotapes of printed materials being considered at the meeting.



City of Rochester

400 Sixth Street
Rochester, MI 48307
P: (248) 733-3700
F: (248) 733-3170
www.rochestermi.org

Procedure for Hybrid Public Meeting

The City has returned to in-person public meetings as of March 14, 2022, with limited online capabilities. The public bodies (our boards and commissions) are meeting in-person; however, some staff, consultants, and guests will still be able to participate remotely. While in-person audience seating is now available, with limited COVID-19 procedures in place, staff asks that anyone who feels sick not attend in-person.

If you choose to participate virtual, please follow the links and information below:

- Live stream audio and video content on two (2) separate streaming platforms available at the City's [YouTube](#) and at the City's website at www.rochestermi.org/201/City-Webcasts. (Click the "Live" links to go there.)
- The City remains committed to accessibility; however, due to the limitations of technology, City staff encourages residents to send an email with your comments to rsvp@rochestermi.org prior to the meeting, but not later than Noon on the day of the meeting, so that your comments can be read into the record. This will decrease the demand on our virtual meeting infrastructure. (After Noon on the day of the meeting, email comments to: bdannunzio@rochestermi.org.)
- For those who prefer to use a telephone to participate, you will need to call (646) 558-8656 and enter meeting **ID: 822 0157 7547**. When prompted, enter a participant number or just touch the # key. During the call, use *9 to raise hand and you will be "called on" by the last 3-digits of your phone number. (For example, my last digits are 8029. Callers will be asked to speak by referencing the last 4-digits of their phone number.) Note: Phone participants will have their numbers masked, for privacy.
- To provide additional opportunity to participate, members of the public are welcome to join the meeting by copying and pasting the following link in their browser: <https://us02web.zoom.us/j/82201577547> (Downloading Zoom is required.)
- We appreciate your understanding as staff will do our best to assist everyone; but, **please be advised for virtual meetings there is a three (3) minute limit for public comments.**

For assistance, or questions accessing and/or making public comment during the meeting, or other support, please reach out to our Deputy City Clerk, Mr. Brian D'Annunzio by email: bdannunzio@rochestermi.org.



City of Rochester

400 Sixth Street
Rochester, MI 48307
P: (248) 651-9061
F: (248) 651-2624
www.rochestermi.org

Mental Health Awareness Month – May 2025

WHEREAS, mental health includes our emotional, psychological, and social wellbeing; it affects how we think, feel, and act; it also affects how we handle stress, relate to others, and make choices; and

WHEREAS, mental health is important for our individual well-being and vitality, as well as that of our families, communities, businesses; and

WHEREAS, nearly 1 in 5 American adults will have a diagnosable mental health condition in any given year and more than 42.5 million U.S. adults live with anxiety disorder, the most common mental health condition in America; and

WHEREAS, May 1 through May 31, 2025, is recognized as Mental Health Awareness month. Mental Health America (MHA) 's 2025 theme is “Turn Awareness into Action”, which celebrates the progress we've made in recognizing the importance of mental health and provides challenges to turn understanding into meaningful steps towards change; and

WHEREAS, Oakland Community Health Network (OCHN) joins our national partners in promoting this year's “Turn Awareness into Action” campaign; and

WHEREAS, mental health management ensures that individuals can focus on their abilities to live, work, learn and fully participate and contribute to our society, while promoting diversity, inclusion, and acceptance; and

WHEREAS, improved systems of care for vulnerable populations, access to non-emergent and crisis services, advanced integrated physical and behavioral health care along with provider relations help to fortify services coordinated by OCHN; and

WHEREAS, OCHN, and its provider agencies, are committed to inspiring hope, empowering people, and strengthening communities.

NOW, THEREFORE, BE IT RESOLVED that, the City of Rochester, hereby recognizes May 2025 as Mental Health Awareness Month. The City of Rochester calls upon our citizens, government agencies, and schools to recommit our state to increasing awareness and understanding of mental illness, and the need for appropriate and accessible services for all people with mental illness to promote recovery and a higher quality of life.

Lee Ann O'Connor, City Clerk

1. CALL TO ORDER

Mayor Salvia at 7:00 p.m.

2. ROLL CALL

PRESENT: Mayor Nancy Salvia, Mayor Pro Tem Stuart Bikson, Councilmembers Christian Hauser, Sara King, Steve Sage and Marilyn Trent.

ABSENT: Councilmember Debbie Jones.

3. PLEDGE OF ALLEGIANCE

Mayor Salvia led the Pledge of Allegiance.

Mayor Salvia announced the passing of Mary Lee Kowalcyk, the former Manager of the Rochester Community House.

4. PUBLIC COMMENT SCHEDULED/NON SCHEDULED/PRESENTATIONS

4A. Presentation from Rochester Hills Museum at Van Hoosen Farm Director Pat McKay.

4B. Presentation from Councilmember Marilyn Trent about the new micro forest to be located near Scott Street Park near the Community Garden.

Public Comment. NONE.

5. CONSENT AGENDA

5A. Minutes for the Regular Meeting of Regular Meetings of March 10, 2025 and March 24, 2025.

MOTION: Trent moved, Hauser seconded,

To approve the Minutes for the Regular Meeting of Regular Meetings of March 10, 2025 and March 24, 2025.

VOTE: YES: Salvia, Bikson, Hauser, King, Sage and Trent.

NO: None.

ABSENT: Jones.

Motion Carried.

5B. Special Event Application from the Paint Creek Center for the Arts to hold Art & Apples Festival on September 5 to 7, 2025 in the Municipal Park.

MOTION: Trent moved, Hauser seconded,

To approve the Special Event Permit for the Paint Creek Center for the Arts to hold Art & Apples Festival on September 5 to 7, 2025 in the Municipal Park.

VOTE: YES: Salvia, Bikson, Hauser, King, Sage and Trent.

NO: None.

ABSENT: Jones.

Motion Carried.

5C. Special Event Application from the Dysautonomia Internation Organization to hold the Detroit POTS 5k run/walk on September 28, 2025 in the Municipal Park.

MOTION: Trent moved, Hauser seconded,
To approve the Special Event Permit for the Dysautonomia Internation Organization to hold the Detroit POTS 5k run/walk on September 28, 2025 in the Municipal Park.

VOTE: YES: Salvia, Bikson, Hauser, King, Sage and Trent.
NO: None.
ABSENT: Jones.

Motion Carried.

5D. Special Event Application from the Rochester Avon Recreation Authority to hold Music in the Park on June 12 & 26, July 10 & 24, and August 16 & 28, 2025 in the gazebo amphitheater at Lions Park.

MOTION: Trent moved, Hauser seconded,
To approve the Special Event Permit for Rochester Avon Recreation Authority to hold Music in the Park on June 12 & 26, July 10 & 24, and August 16 & 28, 2025 in the gazebo amphitheater at Lions Park.

VOTE: YES: Salvia, Bikson, Hauser, King, Sage and Trent.
NO: None.
ABSENT: Jones.

Motion Carried.

5E. Special Event Application from Leader Dogs for the Blind to hold the 2025 Bark & Brew 5k event on June 8, 2025 along City streets ending at the parking lot of Rochester Mills Brewery.

MOTION: Trent moved, Hauser seconded,
To approve the Special Event Permit for Leader Dogs for the Blind to hold the 2025 Bark & Brew 5k event on June 8, 2025 along City streets ending at the parking lot of Rochester Mills Brewery.

VOTE: YES: Salvia, Bikson, Hauser, King, Sage and Trent.
NO: None.
ABSENT: Jones.

Motion Carried.

5F. Special Event Application from The Kiwanis Club of Rochester to hold Music in the Park on June 19 & 26, July 3, 10, 17, 24 & 31, 2025 in the Band Shell in Municipal Park.

MOTION: Trent moved, Hauser seconded,
To approve the Special Event Permit for The Kiwanis Club of Rochester to hold Music in the Park on June 19 & 26, July 3, 10, 17, 24 & 31, 2025 in the Band Shell in Municipal Park.

VOTE: YES: Salvia, Bikson, Hauser, King, Sage and Trent.
NO: None.
ABSENT: Jones.

Motion Carried.

5G. Special Event Application from Back Door Taco & Tequila Bar at 401 S. Main, to hold the Cinco de Mayo event on May 5, 2025 within the 4 parking spaces adjacent to their building on W. Fourth Street.

MOTION: Trent moved, Hauser seconded,
To approve the Special Event Permit for Back Door Taco & Tequila Bar at 401 S. Main, to hold the Cinco de Mayo event on May 5, 2025 within the 4 parking spaces adjacent to their building on W. Fourth Street.

VOTE: YES: Salvia, Bikson, Hauser, King, Sage and Trent.
NO: None.
ABSENT: Jones.

Motion Carried.

6. OLD BUSINESS/ TABLED ITEMS.

NONE.

7. PUBLIC HEARINGS

7A. Public Hearing to consider authorizing issuance of 2025 Capital Improvement Bonds in the amount of \$2,610,000.00 and to approve the Resolution. Tom Colis gave Council an overview of the process.

Mayor Salvia opened the Public Hearing at 7:35 p.m.

No one addressed Council.

Mayor Salvia closed the Public Hearing at 7:37 p.m.

MOTION: Hauser moved, Trent seconded,
To adopt the Resolution authorizing issuance of 2025 Capital Improvement Bonds in the amount of \$2,610,000.00.

VOTE: YES: Salvia, Bikson, Hauser, King, Sage and Trent.
NO: None.
ABSENT: Jones.

Motion Carried.

8. LEGISLATIVE DELIBERATIONS

8A. Resolution confirming the Principal Shopping District Special Assessment District 2025-01. This follows the Public Hearing held March 23, 2025.

MOTION: Trent moved, Hauser seconded,
To adopt the Resolution confirming the Principal Shopping District Special Assessment District 2025-01 including the Roll and Map.

VOTE: YES: Salvia, Bikson, Hauser, King, Sage and Trent.

NO: None.

ABSENT: Jones.

Motion Carried.

9. REPORTS AND REGULAR BUSINESS

9A. Agreement for Labor Attorney services from Elizabeth Young of Shultz Young Law Firm.

MOTION: Hauser moved, King seconded,
To approve the Agreement for Labor Attorney services from Elizabeth Young of Shultz Young Law Firm.

VOTE: YES: Salvia, Bikson, Hauser, King, Sage and Trent.

NO: None.

ABSENT: Jones.

Motion Carried.

9B. Downtown Development Authority Chair Ben Giovanelli and Director Kristi Trevarrow presented the DDA's proposed FYE 2026 budget with changes to cross charges for personnel with the Principal Shopping District to accommodate the opening of The Graham Market.

9C. Downtown Development Authority Director Kristi Trevarrow presented the FYE 2026 Principal Shopping District budget detailing the changes in cross charges to the DDA for personnel and changes to event to address their budget shortfall.

MOTION: King moved, Trent seconded,
To approve the proposed Principal Shopping District FYE 2026 Principal Shopping District budget including the 50/50 personnel cross charges with the DDA, the changes to programs and shift of Big, Bright Light Show to the DDA.

VOTE: YES: Salvia, Hauser, King and Trent.

NO: Bikson and Sage.

ABSENT: Jones.

Motion Carried.

9D. Notice of cancellation of the Public Hearing scheduled for April 28, 2025 for the Zoning Ordinance because the Planning Commission has not completed their review and have not made a recommendation to Council.

MOTION: Hauser moved, Trent seconded,
To cancel the Public Hearing scheduled for April 28, 2025 for the Zoning Ordinance because the Planning Commission has not completed their review and have not made a recommendation to Council.

VOTE: YES: Salvia, Bikson, Hauser, King, Sage and Trent.

NO: None.

ABSENT: Jones.

Motion Carried.

9E. The Developers for 704 Woodward, Champion Development Group, presented their request to begin the process for a Brownfield at the location due to the unexpected costs with contamination clean up. It was originally expected that the clean up would cost about \$1,000,000.00, but the testing exposed more severe contamination than expected. After the presentation, Administration asked Council for a head nod if they agree that the Developer could begin the Brownfield process. Council agreed. The Developer will submit their proposal to the Brownfield Redevelopment Authority for consideration.

9F. Resolution requesting reimbursement for costs for West Nile Virus prevention to Oakland County in the amount of \$1,666.36.

MOTION: Bikson moved, Sage seconded,
To adopt the Resolution requesting reimbursement for costs for West Nile Virus prevention to Oakland County in the amount of \$1,666.36.

VOTE: YES: Salvia, Bikson, Hauser, King, Sage and Trent.

NO: None.

ABSENT: Jones.

Motion Carried.

9G. Check register reports for March 26 and April 3, 2025.

10. BOARDS AND COMMISSIONS REPORTS.

10A. Historical Commission – Sage stated that the headstone cleaning will be May 10, 2025 in preparation for the America 250 celebration next year.

10B. Rochester Area Youth Assistance – report postponed.

10C. Rochester Avon Recreation Authority – King advised there was not a new meeting to report on.

10D. Cemetery Advisory Committee – report postponed.

10E. Planning Commission – Hauser stated there were Public Hearing held on the Community House plans, for 265 E. Second St., for a Special Exception request at 203 E. University and for a façade change at 626 N. Main. They also held the Public hearing for the revised Zoning Ordinance after which in person meeting time for the public was scheduled for April 17.

10F. Sister City Committee – Trent stated they heard for David Work at RARA.

10G. Principal Shopping District – This report was covered earlier.

11. PUBLIC COMMENT

NONE.

12. GENERAL MISCELLANEOUS.

City Clerk O'Connor reminded of the deadline to petitions for City Council election is April 22, 2025 at 4:00 p.m. and the withdrawal deadline is Friday, April 25, 2025 at 4:00 p.m.; she advised that she would be sending the Boards and Commissions applications and list; and she asked Council if there was support for her to work with City Attorney Kragt on a Charter Amendment to eliminate the Primary Election in the future. Council was in favor.

Bikson commented that Mary Lee Kowalczyk created the modern Community House and she will be missed.

Hauser commented on Administration working with Jana Yezak and the Assistance League's concerns with the zoning of the building on South Street.

Mayor Salvia reminded of the Arbor Day tree planting on April 22, that the micro forest ribbon cutting and planting will be May 3, 2025, reminded of Memorial Day events at Mt. Avon Cemetery begin at 8:00 a.m. and she advised that the State of the City address will be held in the Fall.

13. ADJOURN

Mayor Salvia adjourned the meeting at 9:55 p.m.

Lee Ann O'Connor, City Clerk

Nancy Salvia, Mayor

1. CALL TO ORDER

Mayor Salvia at 7:00 p.m.

2. ROLL CALL

PRESENT: Mayor Nancy Salvia, Mayor Pro Tem Stuart Bikson, Councilmembers Christian Hauser, Debbie Jones, Sara King, Steve Sage and Marilyn Trent.

ABSENT: NONE.

3. PLEDGE OF ALLEGIANCE

Mayor Salvia led the Pledge of Allegiance.

4. PUBLIC COMMENT SCHEDULED/NON SCHEDULED/PRESENTATIONS

4A. Rochester Community Schools Orchestra Program by Keenan Thomason.

Public Comment.

Jana Yezak, representative of the Assistance League, thanked Administrative for the progress on their concerns with their building on South Street.

5. CONSENT AGENDA

5A. Special Event Application from Moms Demand Action for Gun Sense in America to hold Gun Violence Awareness Month in June by tying orange ribbons on the lampposts on Main Street.

MOTION: Trent moved, Jones seconded,

To approve the Special Event Permit for Moms Demand Action for Gun Sense in America to hold Gun Violence Awareness Month in June by tying orange ribbons on the lampposts on Main Street.

VOTE: YES: Salvia, Bikson, Hauser, Jones, King, Sage and Trent.

NO: None.

Motion Carried.

5B. Agreement, Joint and Cooperative, with the Southeastern Oakland County Public Works Association for use of Personnel and Equipment During Emergencies.

MOTION: Trent moved, Jones seconded,

To approve the Agreement, Joint and Cooperative, with the Southeastern Oakland County Public Works Association for use of Personnel and Equipment During Emergencies.

VOTE: YES: Salvia, Bikson, Hauser, Jones, King, Sage and Trent.

NO: None.

Motion Carried

5C. Check Register Reports for April 3 and 10, 2025.

MOTION: Trent moved, Jones seconded,
To approve the Check Register Reports for April 3 and 10, 2025.

VOTE: YES: Salvia, Bikson, Hauser, Jones, King, Sage and Trent.

NO: None.

Motion Carried

6. OLD BUSINESS/ TABLED ITEMS.

NONE.

7. PUBLIC HEARINGS

7A. Public Hearing for the Fiscal Year Ending June 30, 2026 budget.

Mayor Salvia opened the Public Hearing at 7:45 p.m.

Jane Turner, Parkdale, asked about electronic speed signs on Parkdale.

Carol Demini, Village Green Apartments, commented on code enforcement of trash dumpsters.

Mayor Salvia closed the Public Hearing at 7:51 p.m.

Downtown Development Authority Director Kristi Trevarrow gave Council a final overview of the Principal Shopping District budget.

Jeanine Offer from the City Beautiful Commission reviewed their annual goals for FYE 26.

MOTION: Hauser moved, Jones seconded,
To adopt the Resolution approving the Fiscal Year 2025 – 2026 budget.

VOTE: YES: Salvia, Bikson, Hauser, Jones, King, Sage and Trent.

NO: None.

Motion Carried

8. LEGISLATIVE DELIBERATIONS

8A. Ordinance Amendment to the City Code, Chapter 8 – Animals, Article I – In General, to add new Section 8-9 – Feeding of Animals, to prohibit ground feeding of animals and stray/feral cats and dogs, Second Reading and Adoption.

MOTION: Hauser moved, King seconded,
To give Second Reading and Adoption to Ordinance 2025-01 an Ordinance Amendment to the City Code, Chapter 8 – Animals, Article I – In General, to add new Section 8-9 – Feeding of Animals, to prohibit ground feeding of animals and stray/feral cats and dogs.

VOTE: YES: Salvia, Hauser, Jones, King and Trent.

NO: Bikson and Sage.

Motion Carried

8B. Traffic Control Order 2025-01, for no parking on the North side of First Street from Fraser to Wilcox.

MOTION: Hauser moved, Sage seconded,
To approve the Traffic Control Order 2025-01, for no parking on the North side of First Street between Fraser to Wilcox.

VOTE: YES: Salvia, Bikson, Hauser, Jones, King, Sage and Trent.

NO: None.

Motion Carried

8C. Traffic Control Order 2025-02, for no parking signs on the south side of Romeo Road between Short and Inglewood.

MOTION: Hauser moved, Trent seconded,
To approve the Traffic Control Order 2025-02, for no parking signs on the south side of Romeo Road between Short and Inglewood.

VOTE: YES: Salvia, Bikson, Hauser, Jones, King, Sage and Trent.

NO: None.

Motion Carried

9. REPORTS AND REGULAR BUSINESS

NONE.

10. BOARDS AND COMMISSIONS REPORTS.

10A. Rochester Avon Recreation Authority – King said they reviewed their budget, that Rochester Hills will have a millage proposal, they are working on their Master Plan, they have opened an e-sports lab and they are taking camp registrations.

10B. Paint Creek Trailway Commission – Sage stated they have put out the Request for Proposals for the bridge work and that Oakland County Parks and Recreation met with them and offered to help with management and updating their Master Plan.

10C. Downtown Development Authority – Trent reminded that the Farmers' Market begins May 3 and will be held on the top level of the East Parking Deck and that they received a report from DDA staff on the conference in Philadelphia they attended.

10D. Tree Committee – Salvia stated that they will be planting the Mother Tree for the micro forest on Arbor Day, April 22 and they discussed the illegal removal of trees by Rochester Place Apartments.

10E. Rochester Area Youth Assistance – Jones stated they are holding a health fair and thanked Councilmember Trent for her business' help on their brochure.

10F. Zoning Board of Appeals – City Manager Banda stated that the board did not take action on the request from 302 Glendale because it was not required.

10G. Historical Commission – Sage noted that 2026 Founders' Day will be March 22, 2026 and will cover the America 250 celebration.

10H. Cemetery Committee – Jones stated there will be headstone cleaning May 10 and the discussed fund raising with Community Foundation of Greater Rochester.

10I. Principal Shopping District – this report was covered earlier.

11. PUBLIC COMMENT

Pat Kane, W. Fourth Street, commented on the micro forest and a legislative Bill regarding certifications for nature related programs.

12. GENERAL MISCELLANEOUS.

City Manager Banda advised that the Department of Natural Resources would be conducting lamprey prevention in the Clinton River.

Trent stated that the planting of the micro forest will be Saturday, May 3, 2025 and they will be planting 290 trees and shrubs.

Hauser said the Blight Committee had met and made progress on the Ordinance Amendment.

Mayor Salvia reminded that there will be office hours for the City Planner to meet with residents about the Zoning Ordinance and she encouraged Council Members to look at the Boards and Commissions list and actively recruit for vacancies.

13. ADJOURN

Mayor Salvia adjourned the meeting at 9:10 p.m.

Lee Ann O'Connor, City Clerk

Nancy Salvia, Mayor

ROCHESTER POLICE DEPARTMENT

400 SIXTH STREET
ROCHESTER, MICHIGAN 48307
PHONE (248) 651-9621
FAX (248) 651-3607
<http://www.rochestermi.org>

GEORGE T. ROUHIB JR.
CHIEF OF POLICE

MEMORANDUM

Date: April 25, 2025
To: Nik Banda, City Manager
From: George T. Rouhib Jr., Chief of Police
Subject: Uplifting Music in the Park Event



Issue: Request to hold the Uplifting Music in the Park event

Analysis: A special event application was submitted by the Bethesda Church to hold an Uplifting Music in the Park event on Sunday, **July 13, 2025**, from 6 pm to 8 pm in the Bandshell and surrounding areas. The application was reviewed by the department heads and no costs were associated with the event. A hold harmless agreement and proof of liability insurance shall be submitted prior to the event.

Requested Action: Review and approve event as presented.

Attachment(s): Special event application

**APPLICATION FOR SPECIAL EVENT PERMIT
PARKS & PUBLIC SPACES**

Complete & sign this form and return to City of Rochester Police Chief along with a non-refundable check made to the City of Rochester
Application fee for first time event \$150, 2nd and subsequent years \$125

Date/Hours of Event:	July 13th, 2025	Date/Hours of Event:	6 pm
----------------------	-----------------	----------------------	------

Name of Event:
Uplifting music in the park

Description of Event:
Music concert in the park including encouragement from speaker in the band shell. Sound team will be setting up sound, church members will sit on their own chairs

Location Requested:
Band shell and surrounding grass area

NOTE: Reservations for the Kiwanis and Lion's Shelters are managed under a separate permit available at City Hall. Please Check availability first by calling City Hall at (248) 733-3700.

Date/Hours of Event: July 13th at 6pm

Date/Hours of Set-up and Tear Down: 12 pm for setup, 8 pm for tear down

Organization Name:
Bethesda church Troy MI

Organization Address (include street address, city, state & zip):
2075 E. Long Lake Rd., Troy MI 48085

Organization Phone Number: 2487407507

Name of Contact Person and Phone Number: Cornel Burca, 2488354183

Contact Person E-Mail (must be provided): burca8501@gmail.com

On-Site Event Manager/Contact Person Name & Phone Number: Cornel Burca, 2488354183

ACKNOWLEDGEMENT

The Rochester City Council shall have sole and complete discretion whether to issue a permit. Nothing contained in the City Code shall be construed to require the City to issue a permit to an applicant, and no applicant shall have any interest or right to receive a permit merely because the applicant has received a permit in the past.

As the authorized agent of the sponsoring organization, I hereby agree that this organization shall abide by all conditions and restrictions specific to the event as determined by the City and will comply with all local, state, and federal rules, regulations, and laws.

C. Burca	4/24/2025
Signature of Applicant	Date

PLEASE COMPLETE THE FOLLOWING EVENT INFORMATION:

EVENT LAYOUT: Please attach all sketches of the layout to the completed Application.

Organization Type: Government Non-Profit For-Profit

List any additional Sponsors or Participants:

Is this event a fundraiser? YES NO
If yes, indicate beneficiary information:

Is this the first time the event is being held in Rochester? YES NO
Describe:

Was this even previously held outside of Rochester? YES NO
Describe:
Yes, years ago in Hart Plaza Detroit

Total estimated attendance each day:
1 day, 150 people

What parking arrangements will be necessary to accommodate attendance?
Describe:
None, we will use parking structure

Is amplification of music or speakers planned or anticipated? YES NO
If yes, describe:
Yes, sound team will setup our speakers

Will volunteer staff be provided to assist with safety, security and maintenance: YES NO
Ushers and security from church. That said, we don't mind help from our great police

Will alcoholic beverages be served? YES NO
If yes, describe:

Will food/beverages be sold? YES NO *NOTE: Public & Vendor permits are required. Also, Health Department approval required for food sales.*
 If yes, describe:

Will merchandise be sold? YES NO
 If yes, describe:

Will the event require the use of any of the following municipal equipment?

Picnic Tables	<input checked="" type="checkbox"/> YES	<input type="checkbox"/> NO	If yes, number requested: <input type="text" value="3"/>
Trash Receptacles	<input checked="" type="checkbox"/> YES	<input type="checkbox"/> NO	If yes, number requested: <input type="text" value="3"/>
Dumpsters	<input type="checkbox"/> YES	<input checked="" type="checkbox"/> NO	If yes, number requested: <input type="text"/>
Electrical Connections	<input checked="" type="checkbox"/> YES	<input type="checkbox"/> NO	If yes, number requested: <input type="text" value="Band shell"/>
Meter Bags	<input type="checkbox"/> YES	<input checked="" type="checkbox"/> NO	If yes, number requested: <input type="text"/>
Barricades	<input type="checkbox"/> YES	<input checked="" type="checkbox"/> NO	If yes, number requested: <input type="text"/>
Traffic Cones	<input type="checkbox"/> YES	<input checked="" type="checkbox"/> NO	If yes, number requested: <input type="text"/>
Other	<input type="checkbox"/> YES	<input checked="" type="checkbox"/> NO	If yes, number requested: <input type="text"/>

Will you be requesting City safety personnel to be assigned to this event (Police/Fire): YES NO
 Describe:
 1 or 2 police officers if available. We appreciate them

Will street closures be necessary? YES NO
 If yes, include a detailed map and indicate the date and time for closing and re-opening including set-up and tear down.
 Describe:

PLEASE INDICATE IF YOU WILL BE REQUIRING, CONSTRUCTING OR LOCATING ANY OF THESE ITEMS IN THE AREA OF THE EVENT:

Kiwanis and/or Lion's Shelter YES NO

*Reservations for the Kiwanis and Lion's Shelters are handled under separate permits available at City Hall.
Please check availability first by calling City Hall at (248) 733-3700.*

Booths YES NO
If yes, indicate number of booths and size of each.

Tents YES NO
If yes, indicate number of tents and size of each.

**The City requires inspection of all tents larger than 10' x 10'. If any of the tents for your event are larger than 10' x 10', please provide the date and time the tent is assembled so an inspection may be scheduled.*

Date: Time:

Awnings YES NO
If yes, number of awnings and size of each:

Canopies YES NO
If yes, number of canopies and size of each:

3 canopies probably 10 x 10 to provide shade to sound team

Tables YES NO
If yes, number of tables and size of each:

Portable Restrooms YES NO
If yes, number of portable restrooms requested and locations:

Other Items Requested YES NO
If yes, describe:

2025 Rochester Event Calendar Tentative Events

April 25, 2025

Month	Time	Event	Location	Reviewed Department Heads	Reviewed City Manager	Council Approval	Costs
January							
17-18	10am-6pm	Downtown Rochester Frost Festival	Downtown Rochester	Yes	Yes	Yes	\$ -
19	9am-11am	Frozen Paw 5K	Downtown Rochester	Yes	Yes	Yes	\$ 2,600
February							
		No Events					
March							
15	1pm-11pm	Friends of Foster Kids Charity-Pre St. Patrick's Day	O'Connors	Yes	Yes	Yes	\$ -
16	Noon-10pm	St. Baldrick's Fundraiser	Corner Bar	Yes	Yes	Yes	
17	7am-2am	Annual St. Patrick's Day Celebration	O'Connors	Yes	Yes	Yes	\$ 250
April							
4	4pm-7pm	Haven Sexual Assault Awareness Month	Downtown Rochester	Yes	Yes	Yes	\$ -
11,12,13	10am-5pm	Knights of Columbus Tootsie Roll Drive	Main/University	Yes	Yes	Yes	\$ -
May							
5	1pm-9pm	Cinco de Mayo	D'Marcos	Yes	Yes	Yes	
10	Noon-3 pm	Detroit Dachshund Club Walk Fundraiser	Paint Creek Trail	Yes	Yes	Yes	\$ -
24	6:30am-5 pm	Heritage Car Show	Municipal Park	Yes	Yes	Yes	\$ -
June							
2	All Day	Gun Violence Awareness Month (June)	Downtown Rochester	Yes	Yes	Yes	
7	8am-10am	OPC 5KRun/Walk-Meals for Wheels	Clinton River Trail	Yes	Yes	Yes	\$ -
8	7am-12pm	Bark & Brew 5K Run	Municipal Park	Yes	Yes	Yes	
12	6pm-9pm	Music in the Park	Lions Park	Yes	Yes	Yes	
19	6:30pm-11:30pm	Movies in the Moonlight	East Parking Deck	Yes	Yes	Yes	\$ -
19	7pm-9pm	Movies in the Park	Municipal Park	Yes	Yes	Yes	\$ -
21	10am-6pm	Makers Market	W. Fourth Street	Yes	Yes	Yes	\$ 500
26	6 pm-9 pm	Music in the Park	Lions Park	Yes	Yes	Yes	\$ -
26	7pm-9pm	Music in the Park	Municipal Park	Yes	Yes	Yes	\$ -
26	6:30pm-11:30pm	Movies in the Moonlight	East Parking Deck	Yes	Yes	Yes	\$ -

5-6	TBD	Kris Kringle Market	Downtown Rochester			
7	2pm-4pm	Christmas Parade	Downtown Rochester			

(For Internal Use Only: City of Rochester Department Review/Comments)

Department	Name	Comments	Costs Expected
City Manager			
DPW/Parks & Recreation	Jill Gaffke	No Issues	0
Police Department	Chief Rouhib	No Issues	0
Fire Department	Chief Cieslik	No Issues	0
Building Department			
Finance Department			
Clerk			
DDA (*If in the district)			

City of Rochester

400 Sixth Street
Rochester, MI 48307
Phone 248-651-9061
Fax 248-651-2624

Receipt

Date	Receipt No.
04/25/2025	314496
Batch No.	Cashier
	ckrenek

Received of:
CORNEL BURCA

Description:

Item	Description	Amount
SPEA	BAND SHELTER	\$125.00

TOTAL:	\$125.00
---------------	-----------------

Check No.	Payment Method	Amount
c790926e-3d2e-42ce-b1ae-2	CREDIT CARD	\$125.00
c790926e-3d2e-42ce-b1ae-2	Credit Card Fee	\$4.06

Account Number	Amount Paid	Remaining Balance
BAND SHELTER	\$125.00	\$0.00

PAID

APR 24 2025

CITY OF ROCHESTER

Signed: _____

Check Date	Check	Vendor Name	Invoice Vendor	Description	Amount
Bank A1 ACCOUNTS PAYABLE					
04/17/2025	140365	21ST CENTURY MEDIA - MICHIGAN	21ST CENTURY MEDIA - MICHIGAN	OAKLAND PRESS LEGAL MARCH 2025	2,317.54
04/17/2025	140366	AMERESCO, INC	AMERESCO, INC	FACILITIES ASSET MANAGEMENT PLAN SEF	4,429.00
04/17/2025	140367	ANDERSON, ECKSTEIN AND	ANDERSON, ECKSTEIN AND	PROJ 0270-0206-0 PRO SERVICES 3/10/	158.10
04/17/2025	140368	ASCENSION MICHIGAN EMPLOYER SC	ASCENSION MICHIGAN EMPLOYER SC	PRE EMPLOYMENT PHYSICAL ZACK SLANEC	48.00
04/17/2025	140369	BEAN & LEAF CAFE	BEAN & LEAF CAFE	REDEEMED GIFT CERTIFICATES	35.00
04/17/2025	140370	BIZZY BUZZ ARTISAN MARKET	BIZZY BUZZ ARTISAN MARKET	REDEEMED GIFT CERTIFICATES	130.00
04/17/2025	140371	BOLOGNA VIA CUCINA	BOLOGNA VIA CUCINA	REDEEMED GIFT CERTIFICATES	680.00
04/17/2025	140372	C & G NEWSPAPERS	C & G NEWSPAPERS	C&G NEWSPAPERS INV 0033210IN	163.40
			C & G NEWSPAPERS	C&G NEWSPAPERS INV 0033210IN	99.80
					<u>263.20</u>
04/17/2025	140373	CADILLAC ASPHALT LLC	CADILLAC ASPHALT LLC	COLD PATCH MATERIAL FOR LOCALS/MAJOF	1,144.80
04/17/2025	140374	CHRISTIAN STOEHR	CHRISTIAN STOEHR	REFUND OVERPAYMENT OF PARKING TICKET	20.00
04/17/2025	140375	CITY OF ROCHESTER HILLS	CITY OF ROCHESTER HILLS	ASSIST ON WATERMAIN BREAK W/VACTOR -	1,230.14
			CITY OF ROCHESTER HILLS	ASSIST WITH VACTORING PLUGGED SEWER	1,148.88
					<u>2,379.02</u>
04/17/2025	140376	CITY OF ROCHESTER-661	CITY OF ROCHESTER-661	JAN 2025 GAS USE FIRE AND POLICE	3,845.16
			CITY OF ROCHESTER-661	FEB 2025 GAS USE FIRE AND POLICE	2,895.48
			CITY OF ROCHESTER-661	MARCH 2025 GAS USE FIRE AND POLICE	3,835.66
					<u>10,576.30</u>
04/17/2025	140377	CMN TV	CMN TV	MEETING VIDEOCASTS MARCH 2025	1,300.00
04/17/2025	140378	DANIEL BACHMANN	DANIEL BACHMANN	TREEBATE PROGRAM 1232 CREEK VIEW DRI	750.00
04/17/2025	140379	DAVEY TREE EXPERT COMPANY	DAVEY TREE EXPERT COMPANY	TREE REMOVAL - (LOCALS) 1167 SYCAMOF	2,925.00
			DAVEY TREE EXPERT COMPANY	STUMP GRINDING - (LOCALS)	520.00
					<u>3,445.00</u>
04/17/2025	140380	DENEK Contracting, Inc.	DENEK Contracting, Inc.	BD Bond Refund	1,500.00
04/17/2025	140381	DOWNTOWN TAROT COMPANY	DOWNTOWN TAROT COMPANY	REDEEMED GIFT CERTIFICATES	25.00
04/17/2025	140382	ELEMENT 22 COMMERCIAL GROUP	ELEMENT 22 COMMERCIAL GROUP	CHIEF FINANCIAL VEHICLE PURCHASES MC	2,302.57
			ELEMENT 22 COMMERCIAL GROUP	CHIEF FINANCIAL VEHICLE PURCHASES MC	4,412.43
					<u>6,715.00</u>
04/17/2025	140383	ESSBE	ESSBE	REDEEMED GIFT CERTIFICATES	25.00
04/17/2025	140384	FIGO SALON	FIGO SALON	REDEEMED GIFT CERTIFICATES	100.00
04/17/2025	140385	GEORGIO'S PIZZA & PASTA	GEORGIO'S PIZZA & PASTA	REDEEMED GIFT CERTIFICATES	210.00
04/17/2025	140386	GREAT AMERICA FINANCIAL SVCS	GREAT AMERICA FINANCIAL SVCS	(INV. 39010626) COPIER, PRINTING CC	1,900.92
04/17/2025	140387	KEITH HERMANS	KEITH HERMANS	UNIFORM ALLOWANCE-HERMANS	75.34
04/17/2025	140388	KELLER THOMA	KELLER THOMA	MARCH 2025 GENERAL MATTERS INVOICE I	331.50
04/17/2025	140389	KIMI K SALON & SPA	KIMI K SALON & SPA	REDEEMED GIFT CERTIFICATES	75.00
04/17/2025	140390	KRUSE AND MUER ON MAIN	KRUSE AND MUER ON MAIN	REDEEMED GIFT CERTIFICATES	1,400.00
04/17/2025	140391	LAWNWORKS, INC.	LAWNWORKS, INC.	PLANT FALL BULBS-BUTTERFLY GDN (926C	1,449.00
04/17/2025	140392	MICHIGAN SHERIFFS' ASSOCIATION	MICHIGAN SHERIFFS' ASSOCIATION	HG TRAINING-HANKEY	925.00
04/17/2025	140393	MICHIGAN STATE POLICE	MICHIGAN STATE POLICE	TRAINING CONFERENCE-DREHMER	300.00
04/17/2025	140394	OAKLAND COUNTY TREASURERS	OAKLAND COUNTY TREASURERS	CLINTON OAKLAND SEWAGE DISPOSAL SYST	182,207.73
04/17/2025	140395	ONSITE WELLNESS LLC	ONSITE WELLNESS LLC	APRIL REWARDS MALL DEPOSIT AND MARC	8,920.00
04/17/2025	140396	PENN STATION EAST	PENN STATION EAST	REDEEMED GIFT CERTIFICATES	80.00
04/17/2025	140397	RETRO FITNESS-ROCHESTER	RETRO FITNESS-ROCHESTER	MEMBERSHIP FEES MARCH 2025	134.91
04/17/2025	140398	ROCHESTER BIKE SHOP	ROCHESTER BIKE SHOP	REDEEMED GIFT CERTIFICATES	50.00
04/17/2025	140399	ROCHESTER HILLS TIRE & SERVICE	ROCHESTER HILLS TIRE & SERVICE	OIL CHANGE-60	38.90

Check Date	Check	Vendor Name	Invoice Vendor	Description	Amount
04/17/2025	140400	ROCHESTER MILLS BEER CO.	ROCHESTER MILLS BEER CO.	REDEEMED GIFT CERTIFICATES	2,825.00
04/17/2025	140401	ROCHESTER PLUMBING & HEATING	ROCHESTER PLUMBING & HEATING	CEMETERY- SNAKED CLOGGED URINAL	448.00
04/17/2025	140402	RON WHITTLE	RON WHITTLE	ZBA CASE FILED IN ROCHESTER BUT S/B	500.00
04/17/2025	140403	ROYAL PARK HOTEL, LLC	ROYAL PARK HOTEL, LLC	REDEEMED GIFT CERTIFICATES	225.71
04/17/2025	140404	S WALTER PACKAGING CORP	S WALTER PACKAGING CORP	INVOICE 127260-00 ROCHESTER DDA MKT	3,851.30
04/17/2025	140405	TELVUE	TELVUE	AV ANNUAL SOFTWARE LICENSE	2,250.00
			TELVUE	AV ANNUAL SOFTWARE LICENSE 4/1/25 -	2,609.25
					<u>4,859.25</u>
04/17/2025	140406	TOMA AND SONS BP INC.	TOMA AND SONS BP INC.	REDEEMED GIFT CERTIFICATES	50.00
04/21/2025	1132 (A)	LAW OFFICES OF JEFFREY S KRAGI	LAW OFFICES OF JEFFREY S KRAGI	PROFESSIONAL SERVICES THROUGH MARCH	12,974.00
				LAW OFFICES OF JEFFREY S KRAGI	4,333.33
					<u>17,307.33</u>
04/21/2025	1133 (A)	LINEAR CONSULTING FIRM LLC	LINEAR CONSULTING FIRM LLC	FIRE PROGRAM DEVELOPMENT	3,360.00
04/21/2025	1134 (A)	NYE UNIFORM	NYE UNIFORM	UNIFORM ALLOWANCE-LUDD	149.50
			NYE UNIFORM	UNIFORM ALLOWANCE-BENNETT	271.85
			NYE UNIFORM	COMMENDATION BARS	40.00
			NYE UNIFORM	UNIFORM ALLOWANCE-LUDD	49.50
			NYE UNIFORM	UNIFORM ALLOWANCE-FLANIGAN	134.50
			NYE UNIFORM	UNIFORM ALLOWANCE-FLANIGAN	385.50
			NYE UNIFORM	UNIFORM ALLOWANCE-FRITSCH	21.00
					<u>1,051.85</u>
04/21/2025	1135 (A)	TK ELEVATOR	TK ELEVATOR	MAINTENANCE CONTRACT FOR CITY HALL &	449.56
04/21/2025	1136 (A)	WINDCAVE INC	WINDCAVE INC	PARKING PLATFORM MONTHLY HOSTING FEE	1,275.00
					<u><u>1,275.00</u></u>
A1 TOTALS:					
Total of 47 Checks:					270,342.26
Less 1 Void Checks:					300.00
Total of 46 Disbursements:					<u><u>270,042.26</u></u>

Check Date	Check	Vendor Name	Invoice Vendor	Description	Amount
Bank A1 ACCOUNTS PAYABLE					
04/24/2025	1137 (A)	FIFTH THIRD BANK	FIFTH THIRD BANK	MARCH 2025 CITY CREDIT CARD	45,299.99
04/24/2025	140407	AL'S AUTO WASH LLC	AL'S AUTO WASH LLC	POLICE CAR WASHES	87.50
04/24/2025	140408	APPLIED CAPITAL	APPLIED CAPITAL	COPIER LEASE	1,114.36
04/24/2025	140409	AUGER KLEIN ALLER ARCHITECTS	AUGER KLEIN ALLER ARCHITECTS	UPDATED CONSTRUCTION DOCUMENTS	33,008.51
04/24/2025	140410	BYERS WRECKER SERVICE INC.	BYERS WRECKER SERVICE INC.	PLACEMENT OF DINING DECKS	950.00
04/24/2025	140411	CHARLES SIBERT	CHARLES SIBERT	MAY STUDIO RENT	2,797.13
04/24/2025	140412	CLARKE MOSQUITO CONTROL	CLARKE MOSQUITO CONTROL	2024 NATULAR TABLETS FOR WNV PROGRAM	1,966.28
04/24/2025	140413	CONSUMERS ENERGY	CONSUMERS ENERGY	MAY 2025 CONSUMERS INVOICES	3,923.11
04/24/2025	140414	COPSPLUS	COPSPLUS	UNIFORM ALLOWANCE-FIRMAN	341.75
04/24/2025	140415	CULLIGAN OF ROMEO	CULLIGAN OF ROMEO	CITY HALL WATER SOFTENER CHARGES 4/	85.00
04/24/2025	140416	CULLIGAN OF ROMEO	CULLIGAN OF ROMEO	CITY HALL WATER SOFTENER - SOLAR 40	24.50
04/24/2025	140417	CULLIGAN OF ROMEO	CULLIGAN OF ROMEO	N GARAGE AND ADMIN BLDGS WATER SOFTE	254.00
04/24/2025	140418	CULLIGAN OF ROMEO	CULLIGAN OF ROMEO	N GARAGE AND ADMIN BLDGS WATER SOFTE	209.50
04/24/2025	140419	CUMMINS BRIDGEWAY, LLC	CUMMINS BRIDGEWAY, LLC	PLANNED MAINTENANCE OF GENERATOR FC	769.85
			CUMMINS BRIDGEWAY, LLC	GENERATOR MAINTENANCE AT LUDLOW PUME	555.03
					<u>1,324.88</u>
04/24/2025	140420	DAN'S EXCAVATING, INC.	DAN'S EXCAVATING, INC.	FROST FESTIVAL ELECTRICAL	1,448.60
			DAN'S EXCAVATING, INC.	WALNUT LIGHT CONTROLLER REPAIR	8,126.93
			DAN'S EXCAVATING, INC.	CITY HALL- REPAIR STREET LIGHT	407.34
					<u>9,982.87</u>
04/24/2025	140421	DAVEY TREE EXPERT COMPANY	DAVEY TREE EXPERT COMPANY	FERTILIZER FOR CITY HALL & COMMUNITY	349.00
			DAVEY TREE EXPERT COMPANY	STUMP GRINDING - (LOCALS) 1167 SYCAM	910.00
					<u>1,259.00</u>
04/24/2025	140422	DR WILLIAM PIETRZYK	DR WILLIAM PIETRZYK	2025 FOUNDERS DAY REFRESHMENT REIMBU	157.03
04/24/2025	140423	ENVIRONMENTAL WOOD SOLUTIONS	ENVIRONMENTAL WOOD SOLUTIONS	STUMPS DROP OFF CHARGE	465.30
04/24/2025	140424	EXTERIOR CONCEPTS	EXTERIOR CONCEPTS	SUNDIAL - BRICK PAVER REPAIR WORK	4,650.00
04/24/2025	140425	FOX CHEVROLET	FOX CHEVROLET	OIL CHANGE-53	110.69
04/24/2025	140426	JEFF FIRMAN	JEFF FIRMAN	MOTOR CASE FOAM	248.15
04/24/2025	140427	MACQUEEN	MACQUEEN	MVP PARTS VEH# 713 - SCREEN CABLE, S	389.55
04/24/2025	140428	MAJIK GRAPHICS INC.	MAJIK GRAPHICS INC.	GRAPHICS- M1	400.00
			MAJIK GRAPHICS INC.	GRAPHICS REPLACE-67	76.00
					<u>476.00</u>
04/24/2025	140429	MAXI AUTOMOTIVE SUPPLY	MAXI AUTOMOTIVE SUPPLY	MAINTENANCE MATERIAL VEH# 640 - ROTC	222.38
			MAXI AUTOMOTIVE SUPPLY	MAINTENANCE MATERIAL VEH# 640 - ROTC	528.56
			MAXI AUTOMOTIVE SUPPLY	MAINTENANCE MATERIAL VEH# 640 - ROTC	(206.78)
					<u>544.16</u>
04/24/2025	140430	MESSINA TRUCKING INC.	MESSINA TRUCKING INC.	CRUSHED CONCRETE, CLASS II SAND, LIM	4,728.20
04/24/2025	140431	NANCY SALVIA	NANCY SALVIA	REIMBURSEMENT FOR OAKLAND COUNTY ECC	85.00
04/24/2025	140432	NICHOLS PAPER & SUPPLY CO	NICHOLS PAPER & SUPPLY CO	JANITORIAL SUPPLIES FOR PARKS/CEMET	420.28
04/24/2025	140433	OAKLAND COUNTY TREASURERS	OAKLAND COUNTY TREASURERS	CLEMIS FEE Q1 2025	6,824.75
04/24/2025	140434	PERCEPTIVE CONTROLS	PERCEPTIVE CONTROLS	SUPPORT SERVICES FOR SEWER & WATER:	237.00
04/24/2025	140435	RUSS MILNE FORD, INC	RUSS MILNE FORD, INC	MAINTENANCE MATERIAL FOR VEH# 640 -	121.88
04/24/2025	140436	SHAUN HAYES	SHAUN HAYES	2025 NATIONAL MAIN STREETS CONFERENC	200.00
04/24/2025	140437	SOCRRA	SOCRRA	HOUSEHOLD HAZARDOUS WASTE DROP OFFS	40.00
04/24/2025	140438	SPENCER OIL COMPANY	SPENCER OIL COMPANY	DYED DIESEL FUEL 446.8 GAL DELIVERED	1,090.15

Check Date	Check	Vendor Name	Invoice Vendor	Description	Amount
			SPENCER OIL COMPANY	87 OCT UNLEADED W/ 10% ETHANOL FUEL	4,732.49
			SPENCER OIL COMPANY	87 OCT UNLEADED W/ 10% ETHANOL FUEL	4,321.84
					<u>10,144.48</u>
04/24/2025	140439	SUSAN M MCCULLOUGH	SUSAN M MCCULLOUGH	APRIL DDA MEETING MINUTES	150.00
			SUSAN M MCCULLOUGH	MARCH DDA MEETING MINUTES	150.00
					<u>300.00</u>
04/24/2025	140440	TAMARA DJEDOVIC	TAMARA DJEDOVIC	REIMBURSEMENT FOR 2 MONTHS ON PARKIN	60.00
04/24/2025	140441	THOMSON REUTERS-WEST	THOMSON REUTERS-WEST	CLEAR SUBSCRIPTION	130.20
04/24/2025	140442	VAN HORN TRUCK PARTS INC.	VAN HORN TRUCK PARTS INC.	MVP OIL STOCK- 5W20 MOTOR OIL, FULL	304.32
04/28/2025	1138(A)	JCI JONES CHEMICALS INC.	JCI JONES CHEMICALS INC.	150 LB CYLINDER CHLORINE DELIVERY TC	2,614.00
			JCI JONES CHEMICALS INC.	150 LB CYLINDER CHLORINE DELIVERY TC	(500.00)
					<u>2,114.00</u>
04/28/2025	1139(A)	PARAGON LABORATORIES INC	PARAGON LABORATORIES INC	APRIL 2025 WATER QUALITY PARAMETERS,	360.00
04/28/2025	1140(A)	STEVEN JEROME JOHNSON II	STEVEN JEROME JOHNSON II	APRIL 16, 2025 INSPECTIONS	211.20
04/28/2025	1141(A)	SUN LIFE FINANCIAL	SUN LIFE FINANCIAL	SUNLIFE POLICY# 934649 ACCT 0002 MAY	12,205.72
					<u><u>12,205.72</u></u>
A1 TOTALS:					
Total of 41 Checks:					148,156.29
Less 0 Void Checks:					0.00
Total of 41 Disbursements:					<u>148,156.29</u>

Check Date	Check	Vendor Name	Invoice Vendor	Description	Amount
Bank A1 ACCOUNTS PAYABLE					
05/01/2025	1142 (E)	BLUE CROSS BLUE SHIELD OF MICH	BLUE CROSS BLUE SHIELD OF MICH	BCBSM 7006068/ERS 5.1-31.25 BILLING	109,695.75
05/01/2025	140443	O'CONNOR'S PUBLIC HOUSE	O'CONNOR'S PUBLIC HOUSE	REDEEMED GIFT CERTIFICATES	430.00
05/01/2025	140444	ASCENSION MICHIGAN EMPLOYER SC	ASCENSION MICHIGAN EMPLOYER SC	PRE EMPLOYMENT PHYSICAL ANDREW PITCH	106.00
05/01/2025	140445	BENESCH	BENESCH	WATER DISTRIBUTION PROJ# 0525-60002C	1,620.00
05/01/2025	140446	BEST CHOICE PRINT & PROMOTIONS	BEST CHOICE PRINT & PROMOTIONS	INVOICE 208008 - IN TOWN MAGAZINE	19,576.48
05/01/2025	140447	BILL RUSSELL	BILL RUSSELL	MARKET MUSIC - OPENING DAY	150.00
05/01/2025	140448	BYERS WRECKER SERVICE INC.	BYERS WRECKER SERVICE INC.	VEHICLE REPAIR	200.00
05/01/2025	140449	CDW GOVERNMENT	CDW GOVERNMENT	EPB LAPTOPS ELECTIONS	2,694.06
05/01/2025	140450	CITY OF ROCHESTER HILLS	CITY OF ROCHESTER HILLS	VEHICLE MAINTENANCE	2,551.31
			CITY OF ROCHESTER HILLS	VEHICLE REPAIR	5,002.36
					<u>7,553.67</u>
05/01/2025	140451	CTS COMPANIES INC	CTS COMPANIES INC	SECURITY SYSTEM TRAINING CENTER	6,926.01
			CTS COMPANIES INC	PHONE SYSTEM CHANGE OVER	280.79
			CTS COMPANIES INC	PHONE SYSTEM CHANGE OVER	374.50
			CTS COMPANIES INC	PHONE SYSTEM CHANGE OVER	381.50
					<u>7,962.80</u>
05/01/2025	140452	DAVEY TREE EXPERT COMPANY	DAVEY TREE EXPERT COMPANY	TREE REMOVAL, STUMP GRINDING, CEMETE	3,965.00
05/01/2025	140453	DTE ENERGY	DTE ENERGY	MAY 2025 DTE INVOICES	19,628.19
05/01/2025	140454	ENVIRONMENTAL WOOD SOLUTIONS	ENVIRONMENTAL WOOD SOLUTIONS	WOOD CHIPS DUMP CHARGE	37.15
05/01/2025	140455	FINAL TOUCH DESIGNS	FINAL TOUCH DESIGNS	REDEEMED GIFT CERTIFICATES	60.00
05/01/2025	140456	JOHNSON CONTROLS FIRE PROTECTI	JOHNSON CONTROLS FIRE PROTECTI	PHONE LINE AND SECURITY SYSTEM ISSUE	2,116.23
05/01/2025	140457	KOGELMANN'S CREEK-SIDE SOD	KOGELMANN'S CREEK-SIDE SOD	500 SQFT KENTUCKY BLUEGRASS FOR CEME	165.00
05/01/2025	140458	KRUSE AND MUER ON MAIN	KRUSE AND MUER ON MAIN	REDEEMED GIFT CERTIFICATES	1,390.00
05/01/2025	140459	LA MARQUISE SALON	LA MARQUISE SALON	REDEEMED GIFT CERTIFICATES	50.00
05/01/2025	140460	MCKENNA ASSOCIATES	MCKENNA ASSOCIATES	PROFESSIONAL SERVICES MARCH 2025	7,357.84
05/01/2025	140461	MICHIGAN ASSOC OF PLANNING	MICHIGAN ASSOC OF PLANNING	MEMBERSHIP RENEWAL MI ASSOC OF PLANN	775.00
05/01/2025	140462	MICHIGAN BUSINESS CONNECTION,	MICHIGAN BUSINESS CONNECTION,	LOAN PAYMENT FOR 265 E SECOND, LOAN	15,143.31
05/01/2025	140463	MR C'S CAR WASH #6 LLC	MR C'S CAR WASH #6 LLC	VEHICLE MAINTENANCE	25.50
05/01/2025	140464	MUNICIPAL EMERGENCY SERVICES,	MUNICIPAL EMERGENCY SERVICES,	REPAIR PARTS	101.54
05/01/2025	140465	OAKLAND COUNTY TREASURERS	OAKLAND COUNTY TREASURERS	FRMS REPROT SERVICES	1,207.25
05/01/2025	140466	PAUL'S ON MAIN	PAUL'S ON MAIN	REDEEMED GIFT CERTIFICATES	940.00
05/01/2025	140467	QUALITY BUSINESS ENGRAVING	QUALITY BUSINESS ENGRAVING	RIBBON CUTTING HEARTHSTONE HOSPICE	28.00
05/01/2025	140468	RESALE CONNECTION	RESALE CONNECTION	REDEEMED GIFT CERTIFICATES	25.00
05/01/2025	140469	REZ-COMM, INC	REZ-COMM, INC	SIDEWALK REPLACEMENTS (LOCALS) - 53C	3,007.50
05/01/2025	140470	ROAD COMMISSION OF OAKLAND CO.	ROAD COMMISSION OF OAKLAND CO.	TRAFFIC SIGNAL MAINTENANCE-DTE ENERG	884.81
05/01/2025	140471	ROCHESTER CHOP HOUSE AND	ROCHESTER CHOP HOUSE AND	REDEEMED GIFT CERTIFICATES	1,340.00
05/01/2025	140472	ROCHESTER CORNER BAR	ROCHESTER CORNER BAR	REDEEMED GIFT CERTIFICATES	100.00
05/01/2025	140473	ROCHESTER HILLS TIRE & SERVICE	ROCHESTER HILLS TIRE & SERVICE	REDEEMED GIFT CERTIFICATES	50.00
05/01/2025	140474	TALULAH BELLE	TALULAH BELLE	REDEEMED GIFT CERTIFICATES	150.00
05/01/2025	140475	THE EASTMAN	THE EASTMAN	REDEEMED GIFT CERTIFICATES	30.00
05/01/2025	140476	VAN HORN TRUCK PARTS INC.	VAN HORN TRUCK PARTS INC.	MVP PARTS FOR VEH# 724 - FILTER	55.99
			VAN HORN TRUCK PARTS INC.	MVP PARTS FOR VEH# 724 - FILTERS	167.97
					<u>223.96</u>
05/01/2025	140477	WOLVERINE FREIGHTLINER-	WOLVERINE FREIGHTLINER-	MVP REPAIR PARTS FOR VEH #638 - FLR5	171.99
05/05/2025	1143 (A)	CIVIC PLUS	CIVIC PLUS	CIVIC PLUS ONLINE CODE HOSTING	1,000.00
05/05/2025	1144 (A)	CONTRACTORS CONNECTION INC.	CONTRACTORS CONNECTION INC.	DPW TOOLS & SAFETY EQUIPMENT - SAFET	618.50
05/05/2025	1145 (A)	EASYPERMIT POSTAGE	EASYPERMIT POSTAGE	POSTAGE REFILL PERMIT #1091 - APR 2C	546.18
05/05/2025	1146 (A)	NYE UNIFORM	NYE UNIFORM	UNIFORMS	56.50
05/05/2025	1147 (A)	SUN LIFE FINANCIAL	SUN LIFE FINANCIAL	SUNLIFE MONTHLY VOLUNT POLICY 834645	2,443.78

05/08/2025 03:24 PM
User: CMEYERS
DB: Rochester

CHECK REGISTER FOR CITY OF ROCHESTER
CHECK DATE FROM 05/01/2025 - 05/05/2025

Check Date	Check	Vendor Name	Invoice Vendor	Description	Amount
A1 TOTALS:					
Total of 41 Checks:					213,626.99
Less 0 Void Checks:					0.00
Total of 41 Disbursements:					<u>213,626.99</u>



City of Rochester

400 Sixth Street
Rochester, MI 48307
P: (248) 651-9061
F: (248) 651-2624
www.rochestermi.org

MEMORANDUM

Date: May 7, 2025

To: Nik Banda, City Manager

From: Jeffrey S. Kragt

Subject: Charter Amendment Resolution– Eliminate Primary Election Provisions

Copies: Lee Ann O'Connor, Jeremy Peckens, Holly Meyers, Megan Frazho

Issue: Consideration of Charter Amendment Resolution to Eliminate Primary Elections.

Analysis: As Council knows, there have been significant changes in election law in the state of Michigan. That includes increased absentee ballot utilization, the addition of early voting, etc. Clerk O'Connor has kept up with and advised Council of the changes. Recently, she presented the opportunity to consolidate precincts and polling locations, which Council approved.

During this process, Clerk O'Connor considered the issue of primary elections, especially in light of the possibility of a primary election being required for the 2025 election cycle. Her review of the issue included discussions with the Oakland County Elections Department, which indicated that Rochester is one of only 8 communities in Oakland County that have provisions on the books for primary elections. Having primary election language is not required under state law. Rochester's principal primary election provisions are found in Section 5.3 of the City's Charter. A primary is triggered if the number of candidates reaches twice the seats open plus one. Thus, typically there are 4 seats open every odd year, so a primary would trigger if there were 9 candidates (2 x 4 seats plus 1).

Clerk O'Connor floated the idea of removing the primary election language at a recent Council meeting and Council expressed support for such an action. The County also expressed its favor in removing the primary election language. While the City has not had a primary for quite some time, if there was one triggered, it would be quite expensive considering the requirement to automatically send absentee ballots to those on the permanent absentee ballot list, which is presently at over 3,000. It would also eliminate the need for the candidates to prepare and expend funds for both a primary and regular election.

This would take a charter amendment. Attached is a resolution that would be the 1st step in the process. The Resolution sets forth the proposed Charter changes (redlined much like an ordinance amendment), the current Charter language, and also proposed ballot language. If Council wishes to proceed with the process, then it would pass the Resolution. Charter amendments have to be submitted the Governor's office and the Attorney General's office for review and approval before it can be submitted to the County for inclusion on the ballot. There are Code provisions addressing primary elections as well, but we would prepare the necessary amendments if/when the voters approve the Charter Amendment.

Requested Action: If City Council wishes to proceed, the requested action would be to adopt the attached Resolution and direct City Clerk and City Attorney to take the necessary steps to present to the Governor's office, the Attorney General's office and submit the matter on the November 4, 2025 election ballot.

Attachment: Proposed Resolution for Charter Amendment.

**CITY OF ROCHESTER RESOLUTION
APPROVING CHARTER AMENDMENT TO ELIMINATE PRIMARY ELECTIONS
AND THE BALLOT LANGUAGE FOR CHARTER AMENDMENT**

Section 21(1) of the Home Rule City Act (HRCA), MCL 117.21(1), authorizes a city council to adopt a resolution proposing to amend the City Charter by a three-fifths vote of its members-elect, and the resolution proposing to amend the City Charter must set forth the exact wording of the proposed amendment to be submitted to the City voters for approval at a regular or special election, and;

The resolution must set forth the ballot language for the proposed charter amendment—with each proposal being limited to a single subject, and if the subject of a proposal includes more than one related proposition, each proposition shall be separately stated as a ballot proposal to afford an opportunity for a separate vote of the City voters for or against each proposition, and

Section 21(2) of the HRCA, MCL 117.21(2), requires that the ballot language for the submission to the City voters of each proposed amendment, including any separate statement of purpose, shall be limited to 100 words, exclusive of caption, shall be a fair and impartial statement of the purpose of the amendment, and shall not create prejudice for or against the proposed amendment,

I. The Rochester City Council resolves that:

CHARTER AMENDMENT PROPOSAL

1. The Rochester City Charter shall be amended as follows:

Section 5.3. —~~Primary Election:~~ RESERVED

~~A nonpartisan City primary election shall be held, if necessary, in August of every odd numbered year. If, upon the expiration of the time for filing nomination petitions for the officers of the City with respect to which elections are to be held at the next regular City election, it appears that petitions have been filed for no more than twice the number of candidates for each such office, then no primary election shall be held and the Clerk shall publish notice of such fact. It is the intent of this section that if a primary is required for any office, it shall be held for all offices which are to be filled at the next regular City election. The candidates for nomination for each City office to be filled at the next City election, in number equal to twice the number of persons to be elected to such City office, receiving the highest number of votes at any such City primary election shall be declared the nominees for election to the respective offices for which they are candidates for election and their names, and the names of persons filing petitions, or in whose behalf petitions have been filed, in cases where no primary election was held, shall be certified to the election commission to be placed upon the ballot for the next subsequent regular City election. No person whose name is not printed on the primary election ballot, but whose name is written on or appears on the ballot on a sticker pasted thereon at such election, except such stickers as have been placed thereon by the election commission as provided by law, shall be nominated for election to any office, unless he shall receive at least twenty five (25) votes nominating him for such office.~~

Section 5.10. — Nomination Petitions

Persons desiring to qualify as candidates for nomination for any elective office under this Charter shall file a petition therefor with the Clerk signed by not less than twenty-five (25) nor more than fifty (50) registered electors of the City ~~and within the timeframes required under state law not later than 5:00 p.m. on the fourth Friday prior to the date of the regular City primary election.~~ Official blank petitions in substantially the same form as required by State Law for State and County officers, except for references to party, shall be prepared and furnished by the Clerk. Before the Clerk shall furnish any nomination petitions to any person, he shall enter thereon in ink the name of the person desiring to become a candidate for office in the City, or the person in whose behalf the petition is to be circulated, and the name of the office for which he is a candidate. Nomination petitions for the purpose of filling a vacancy shall so state in connection with the name of the office for which the petition is to be circulated. The Clerk shall publish notice of the last day and time for filing nomination petitions at least one (1) week before and not more than three (3) weeks before date. No person shall sign his name to a greater number of petitions for any one office than there will be persons elected to said office. Where any name appears on more petitions than there are candidates to be elected to said office, such name shall not be counted upon any petition for that office.

Section 5.14. – Canvass of Votes:

All votes cast at City ~~primary and~~ general elections shall be canvassed as provided by law by a City Board of Canvassers established in accordance with State Law. The Board shall meet on the first Thursday after each City election and shall determine the vote upon all questions and propositions and declare whether the same have been adopted or rejected and what persons have been ~~nominated or~~ elected at such election. The person, or persons, where more than one are to be ~~nominated for or~~ elected to the same office, who shall receive the greatest number of votes shall be declared to be nominated or elected, as the case may be.

2. The current Charter section(s) being altered by this Amendment provides as follows:

Section 5.3. - Primary Election:

A nonpartisan City primary election shall be held, if necessary, in August of every odd numbered year. If, upon the expiration of the time for filing nomination petitions for the officers of the City with respect to which elections are to be held at the next regular City election, it appears that petitions have been filed for no more than twice the number of candidates for each such office, then no primary election shall be held and the Clerk shall publish notice of such fact. It is the intent of this section that if a primary is required for any office, it shall be held for all offices which are to be filled at the next regular City election. The candidates for nomination for each City office to be filled at the next City election, in number equal to twice the number of persons to be elected to such City office, receiving the highest number of votes at any such City primary election shall be declared the nominees for election to the respective offices for which they are candidates for election and their names, and the names of persons filing petitions, or in whose behalf petitions have been filed, in cases where no primary election was held, shall be certified to the election commission to be placed upon the ballot for the next subsequent regular City election. No person whose name is not printed on the primary election ballot, but whose name is written on or appears on the ballot on a sticker pasted thereon at such election, except such stickers as have been placed thereon by the

election commission as provided by law, shall be nominated for election to any office, unless he shall receive at least twenty-five (25) votes nominating him for such office.

Section 5.10. – Nomination Petitions

Persons desiring to qualify as candidates for nomination for any elective office under this Charter shall file a petition therefor with the Clerk signed by not less than twenty-five (25) nor more than fifty (50) registered electors of the City not later than 5:00 p.m. on the fourth Friday prior to the date of the regular City primary election. Official blank petitions in substantially the same form as required by State Law for State and County officers, except for references to party, shall be prepared and furnished by the Clerk. Before the Clerk shall furnish any nomination petitions to any person, he shall enter thereon in ink the name of the person desiring to become a candidate for office in the City, or the person in whose behalf the petition is to be circulated, and the name of the office for which he is a candidate. Nomination petitions for the purpose of filling a vacancy shall so state in connection with the name of the office for which the petition is to be circulated. The Clerk shall publish notice of the last day and time for filing nomination petitions at least one (1) week before and not more than three (3) weeks before date. No person shall sign his name to a greater number of petitions for any one office than there will be persons elected to said office. Where any name appears on more petitions than there are candidates to be elected to said office, such name shall not be counted upon any petition for that office.

Section 5.14. – Canvass of Votes:

All votes cast at City primary and general elections shall be canvassed as provided by law by a City Board of Canvassers established in accordance with State Law. The Board shall meet on the first Thursday after each City election and shall determine the vote upon all questions and propositions and declare whether the same have been adopted or rejected and what persons have been nominated or elected at such election. The person, or persons, where more than one are to be nominated for or elected to the same office, who shall receive the greatest number of votes shall be declared to be nominated or elected, as the case may be.

3. The ballot language for the proposed Amendment shall be as follows:

CHARTER AMENDMENT PROPOSAL

It is proposed that Sections 5.3, 5.10 and 5.14 of the Charter of the City of Rochester be amended to remove language regarding and providing for primary elections.

Shall this Amendment as proposed be adopted?

Yes ____ No ____

II. The Rochester City Council further resolves that:

The City Clerk shall transmit a certified copy of this Resolution to the Governor of the State of Michigan for approval of the proposed amendments (MCL 117.22) and transmit a certified copy of this Resolution to the Attorney General of the State of Michigan for approval of the proposed ballot language for the proposed Amendments (MCL 117.21).

III. The Rochester City Council further resolves that:

The proposed amendments shall be submitted to the qualified electors of the City of at the general election to be held in the City on November 4, 2025, and the City Clerk is directed to give notice of the election and notice of registration in a manner prescribed by law and to do all things and to provide all supplies necessary to submit the Charter amendments to a vote of the electors as required by law.

IV. The Rochester City Council further resolves that:

The proposed Charter Amendments shall be published in full, together with the existing Charter provision amended as required by law.

Moved by: _____

Seconded by: _____

Ayes: _____

Nays: _____

Absent: _____

Abstained: _____

Motion carried.

I, Lee Ann O’Connor, Clerk of the City of Rochester, certify that the foregoing is a true and compared copy of a Resolution duly adopted by the Rochester City Council at a meeting held on _____, 2025.

/s/ _____
Lee Ann O’Connor, City Clerk



City of Rochester

400 Sixth Street
Rochester, MI 48307
P: (248) 651-9061
F: (248) 651-2624
www.rochestermi.org

MEMORANDUM

Date: May 1, 2025

To: Nik Banda, City Manager

From: Jeffrey S. Kragt

Subject: Termination and Release of Easement – 203 E. University

Copies: Lee Ann O'Connor, Jeremy Peckens, Kristi Trevarrow, Holly Meyers, Megan Frazho

Issue: Consideration of a Termination and Release of Easement – 203 E. University

Analysis: In 1993, the then owners of 203 E. University (which is the Depot building) granted the City an Easement granting it access to and ability to maintain the plaza area. A copy of the “Grant of Easement” is attached.

There is a new owner of the property and he currently has a site plan pending with the Planning Commission for consideration. As part of the site plan discussion, the topic of the plaza Easement has arisen. Neither party has an interest in the City/DDA continuing with the Easement or the responsibilities thereunder. Thus, it was determined that a document to terminate the Easement would be appropriate.

I have prepared a Termination and Release of Easement for Council’s consideration. It is a simple document that identifies and attaches the 1993 Easement, and then provides that the City terminates and releases the ability to enter the property and maintain the plaza area. The new owner will thereafter be responsible for the area like any other portion of the property.

Requested Action: For City Council to approve the Termination and Release of Easement as presented, and authorize the Mayor and City Clerk to execute it on behalf of the City. The document would then be recorded with the Oakland County Register of Deeds.

Attachment(s): 1993 Grant of Easement

LIBER 14542rc045

GRANT OF EASEMENT
 REG/DEEDS PAID
 0001 MAR.21'94 04:20PM
 \$174 MISC 11.00
 (Plaza/Public Access Area)

REG/DEEDS PAID
 0001 MAR.21'94 04:20PM
 \$174 RMT FEE 2.00

KNOW ALL MEN BY THESE PRESENTS, that **DEPOT PLAZA**

PROPERTIES, INC., a Michigan corporation of 203 East University, Rochester, Michigan 48307, (hereinafter "Grantor") for ONE DOLLAR AND NO/100 (\$1.00) and other valuable consideration do hereby grant unto the **CITY OF ROCHESTER**, a Michigan municipal corporation, of 400 Sixth Street, Rochester, Michigan 48307, (hereinafter "Grantee") an easement for the right to occupy, construct, replace, repair and maintain for public access a "plaza area" wherein Grantee may construct, replace, repair and maintain sidewalks, landscaping, lighting, lawns, planting and such other amenities consistent with such an area as in its sole discretion may be beneficial to the general public.

The easement rights for the purposes set forth above shall run with, upon and over the following described property:

A part of the Southwest 1/4 of Section 11, Town 3 North, Range 11 East, City of Rochester, Oakland County, Michigan, described as: Commencing at the Southwest corner of Section 11, thence North 33.00 feet; thence N89°20'00"E 370.00 feet for a POINT OF BEGINNING; thence North 44.00 feet; thence N39°50'00"W 35.83 feet; thence N57°29'00"E 53.82 feet; thence S50°46'00"E 46.05 feet; thence S39°14'99"W 30.00 feet; thence S50°46'00"E 74.24 feet; thence S89°20'00"W 96.64 feet to the POINT OF BEGINNING. Containing 5,967 square feet or 0.1247 acres, more or less.

11.00
2.00 Rmt

Part of 15-11-352-009

BESOUT, POTERE, COX, HUGHES & O'MARA, P.C.
 ATTORNEYS AT LAW
 1000 WEST UNIVERSITY DRIVE
 ROCHESTER, MICHIGAN 48307
 313-651-4114

14542-046

AND A PARCEL DESCRIBED AS:

Commencing at the Southwest corner of Section 11; thence North 33.00 feet; thence N89°20'00"E 460.60 feet for a POINT OF BEGINNING; thence N39°14'00" E 24.25 feet; thence S50°46'00"E 14.00 feet; thence S19°17'00"W 10.24 feet; thence S89°20'00"W 22.80 feet to the POINT OF BEGINNING. Containing 280 square feet or 0.0064 acres, more or less.

Tax Parcel No. Part 15-11-352-009 Sec 11

to have and to hold the said easement rights for a plaza area herein granted to the Grantee and its successors forever.

BINDING NATURE

It being understood that this Easement shall be binding upon and inure to the benefit of the parties hereto, their successors and assigns.

IN WITNESS WHEREOF, the Grantors have executed this Grant Of Easement this 20th day of DECEMBER, 1993.

WITNESSES:

DEPOT PLAZA PROPERTIES, INC.,
a Michigan corporation

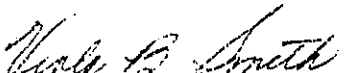
Viola B. Smith

By: 
Lawrence R. Smith
Its President

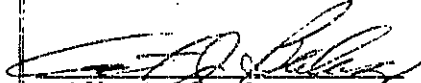
Albert A. Balaz

By: 
Nancy Wheeler
Its Secretary

SEBOUT, POTERE, COX, HUGHES & O'MARA, P.C.
ATTORNEYS AT LAW
MEADOWBROOK PROFESSIONAL PLAZA
1000 WEST UNIVERSITY DRIVE
ROCHESTER, MICHIGAN 48307
313-551-4114

14542rc047

STATE OF MICHIGAN)
) ss.
County of Oakland)

On this 20th day of DECEMBER, 1993, before me, a Notary Public, personally came Lawrence R. Smith and Nancy Wheeler, who being by me duly sworn, did for themselves say that they are the President and Secretary respectively of DEPOT PLAZA PROPERTIES, INC., a Michigan corporation, and the corporation named in and which executed the within instrument, and that the seal affixed to said instrument is the corporate seal of the said corporation, and that said instrument was signed and sealed on behalf of said corporation by authority of its Board of Directors, and said President and Secretary acknowledged said instrument to be the free act and deed of said corporation.

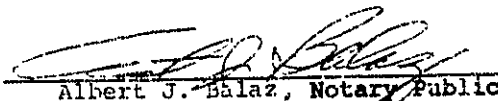
Albert J. Balaz, Notary Public

MACOMB, acting in Oakland County, Michigan
My Commission Expires: October 16, 1995

BEBOUT, POTERE, COX, HUGHES & O'MARA, P.C.
ATTORNEYS AT LAW
1000 WEST UNIVERSITY DRIVE
ROCHESTER MICHIGAN 48307
313 651-4114

Instrument drafted by:

ARTHUR R. COX (P12284)
Bebout, Potere & Cox, P.C.
1000 West University Drive, Suite 314
Rochester, Michigan 48307

RETURN TO:

NANCY D. MILLER, Clerk
City of Rochester
400 Sixth Street
Rochester, Michigan 48307

TERMINATION AND RELEASE OF EASEMENT

This Termination and Release of Easement (“Termination”) is made and executed this ____ day of May, 2025, by the **CITY OF ROCHESTER**, a Michigan municipal corporation (the “City”), whose address is 400 Sixth Street, Rochester, MI 48307.

RECITALS

- A. The City currently is the Grantee of an easement over lands located at 203 E. University, in the City of Rochester, Oakland County, Michigan, pursuant to that certain Grant of Easement recorded in **Liber 14542, Page 045**, Oakland County Register of Deeds, a copy of which is attached hereto as Exhibit A (the “Easement”).
- B. The Easement pertains to the right to occupy, construct, repair and maintain a certain plaza area on the property. City is willing to terminate the Easement and relinquish its rights regarding the plaza area.

NOW, THEREFORE,

1. The undersigned does by the recording hereof terminate, waive and vacate the Easement identified above.
2. The undersigned hereby confirms that the land previously encumbered by the Easement shall, upon the recording of this instrument, be held, conveyed, hypothecated, encumbered, leased, rented, occupied and improved, or in any other manner utilized, free from the benefits and provisions of the Easement.

CITY OF ROCHESTER, a Michigan municipal corporation

By: _____
Nancy Salvia, Mayor

And: _____
Lee Ann O’Connor, City Clerk

STATE OF MICHIGAN)
)SS
COUNTY OF OAKLAND)

The foregoing instrument was acknowledged before me this _____ day of May, 2025 by Nancy Salvia, Mayor of the City of Rochester, and Lee Ann O'Connor, Clerk of the City of Rochester, a Michigan municipal corporation.

Notary Public, acting in Oakland County, MI

My commission expires _____

DRAFTED BY AND WHEN RECORDED
RETURN TO:

Jeffrey S. Kragt
Law Offices of Jeffrey S. Kragt, PLLC
410 W. University Dr., Ste. 200
Rochester, MI 48307

EXHIBIT A
EASEMENT

See attached



City of Rochester

400 Sixth Street
Rochester, MI 48307
P: (248) 651-9061
F: (248) 651-2624
www.rocheatermi.org

MEMORANDUM

Date: April 7, 2025
To: Mayor Salvia and Council Members
From: Nicholas Schaefer, Director of Public Works
Jason Dickinson, Superintendent DPW
Subject: 2025 CDBG Municipal Park Trail

Budget Impact: CDBG Funds \$100,179.92
GL-631-751.000-930.035 Path Maintenance \$21,400.08

Issue: On September 17, 2024, bids for the reference project at the City of Rochester were publicly opened. The certified low bidder for the project is Bowen Paving, Inc. Recently Bowen Paving was purchased by Mierzwa Inc. with the low bid of \$56,561.21.

Analysis: The City Staff work like to award the project to Mierzwa Paving Inc., for the path improvements to the Municipal Park Trail in this years Community Development Block Grant, with the additional funds that was recently reallocated from last year's project in the amount of \$53,964.22.

Requested Action: Approval of the contract with Mierzwa Paving for the path improvement project to the Municipal Park Trail. In the total project amount with 10% contingency of \$121,580.

Attachment(s):

- (1) Project Recommendation Letter
- (2) Tabulation of Bids
- (3) Mapping of Path Improvements



ANDERSON, ECKSTEIN & WESTRICK, INC.

CIVIL ENGINEERS - SURVEYORS - ARCHITECTS

Shelby Township - Roseville - Livonia

586.726.1234 | www.aewinc.com

May 6, 2025

Nick Schaefer, Public Works Director
City of Rochester
1141 N. Wilcox
Rochester, Michigan 48307

Reference: Recommendation of Award of Contract

2025 CDBG Municipal Park Trail

AEW Project No. 0270-0205

Dear Mr. Schaefer:

Following public advertisement and bid solicitation, bids for the referenced project at the City of Rochester were publicly opened on September 17, 2024. The certified low bidder for the project is Bowen Paving, Inc. from Pontiac MI with a total base bid of \$56,561.21. We have attached the bid tabulation for your reference.

It is our understanding that additional CDBG funds were recently reallocated to the Municipal Park Trail project, allowing for an expanded scope of work to be added to the original bid. The additional scope of work, see attached, was shared with the Oakland County CDBG Compliance Unit, and we were informed that it is eligible for the use of the additional funds. Therefore, the City is including this additional work to the original bid. The estimated cost for the additional work is \$53,964.22.

We recommend that this contract be awarded to Bowen Paving, Inc., as they are qualified to perform this work and have successfully completed similar projects in the past.

Furthermore, we recommend that the City award the project with a 10% contingency to cover the costs for unforeseen conditions that may be encountered during the construction phase, resulting in a total amount of \$121,580.00 (Original Bid cost \$56,561.21 + Additional Work cost \$53,964.22+ 10% contingency).



Nick Schaefer, Public Works Director

5/6/2025

Page 2

It is our understanding that the Community Development Block Grant (CDBG) will be utilized for this project and the City will be responsible for any additional costs beyond what the grant will cover.

Sincerely,

Aseel Putros, PE, CFM
Senior Project manager

Enclosure: Bid Tabulation

cc: Lee Ann O'Conner, City Clerk
Nik Banda, City Manager

M:\0270\0270-0205\Project Mgmt\Correspondence\Recommmed of Award.docx



TABULATION OF BIDS
CITY OF ROCHESTER
CDBG FUNDED ROCHESTER
MUNICIPAL PARK PATH IMPROVEMENTS
AEW PROJECT NO. 0270-0205

DATE: 9/17/2024
TIME: 10:00 AM

Prepared by Anderson, Eckstein and Westrick, Inc.
51301 Schoenherr Road
Shelby Township, MI 48315

BIDDER RANKING

RANK	BIDDER'S NAME	TOTAL BID
1	Bowen Paving, Inc.	\$ 56,561.21
2	Jacklyn Contracting, LLC	\$ 78,060.00 *
3	Hutch Paving, Inc.	\$ 80,269.57 *
4	Pro-Line Asphalt Paving Corporation	\$ 148,430.00

* CORRECTED BY ENGINEER



TABULATION OF BIDS

CITY OF ROCHESTER

CDBG FUNDED ROCHESTER

MUNICIPAL PARK PATH IMPROVEMENTS

AEW PROJECT NO. 0270-0205

Bowen Paving, Inc.
1001 Cesar E. Chavez Avenue
Pontiac, MI 48340

Jacklyn Contracting, LLC
PO Box 149
Dryden, MI 48428

Item No.	Description	Estimated Quantity	Units	Unit Price	Amount	Unit Price	Amount
1.	_Mobilization, \$5,000.00 Max	1	LS	5,000.00	5,000.00	5,000.00	5,000.00
2.	_Pathway, Rem, Modified	467	Syd	7.50	3,502.50	15.00	7,005.00
3.	Erosion Control, Silt Fence	420	Ft	2.25	945.00	5.00	2,100.00
4.	_Shared Use Path, Grading, Modified	420	Ft	10.20	4,284.00	15.00	6,300.00
5.	_Aggregate Base, 6 inch, Modified	537	Syd	15.83	8,500.71	15.00	8,055.00
6.	Subgrade Undercutting, Type I	50	Cyd	60.00	3,000.00	50.00	2,500.00
7.	_Shared Use Path, HMA, 4EO3	108	Ton	163.00	17,604.00	250.00	27,000.00
8.	_Shared Use Path, HMA, 5EO3	51	Ton	163.00	8,313.00	300.00	15,300.00
9.	_Surface Restoration, Seeding	280	Syd	16.65	4,662.00	10.00	2,800.00 *
10.	Traffic Control and Maintenance	1	LS	750.00	750.00	2,000.00	2,000.00
TOTAL BID AMOUNT				\$	56,561.21	\$	78,060.00 *

*** CORRECTED BY ENGINEER**



TABULATION OF BIDS

CITY OF ROCHESTER

CDBG FUNDED ROCHESTER

MUNICIPAL PARK PATH IMPROVEMENTS

AEW PROJECT NO. 0270-0205

Hutch Paving, Inc.
3000 E. 10 Mile Road
Warren, MI 48091

Pro-Line Asphalt Paving Corporation
11797 29 Mile Road
Washington, MI 48095

Item No.	Description	Estimated Quantity	Units	Unit Price	Amount	Unit Price	Amount
1.	_Mobilization, \$5,000.00 Max	1	LS	5,000.00	5,000.00	5,000.00	5,000.00
2.	_Pathway, Rem, Modified	467	Syd	21.41	9,998.47	20.00	9,340.00
3.	Erosion Control, Silt Fence	420	Ft	1.95	819.00	7.00	2,940.00
4.	_Shared Use Path, Grading, Modified	420	Ft	3.57	1,499.40	70.00	29,400.00
5.	_Aggregate Base, 6 inch, Modified	537	Syd	19.05	10,229.85 *	40.00	21,480.00
6.	Subgrade Undercutting, Type I	50	Cyd	75.00	3,750.00	20.00	1,000.00
7.	_Shared Use Path, HMA, 4EO3	108	Ton	247.22	26,699.76	250.00	27,000.00
8.	_Shared Use Path, HMA, 5EO3	51	Ton	293.59	14,973.09	370.00	18,870.00
9.	_Surface Restoration, Seeding	280	Syd	22.50	6,300.00	30.00	8,400.00
10.	Traffic Control and Maintenance	1	LS	1,000.00	1,000.00	25,000.00	25,000.00
TOTAL BID AMOUNT				\$	80,269.57 *	\$	148,430.00

*** CORRECTED BY ENGINEER**

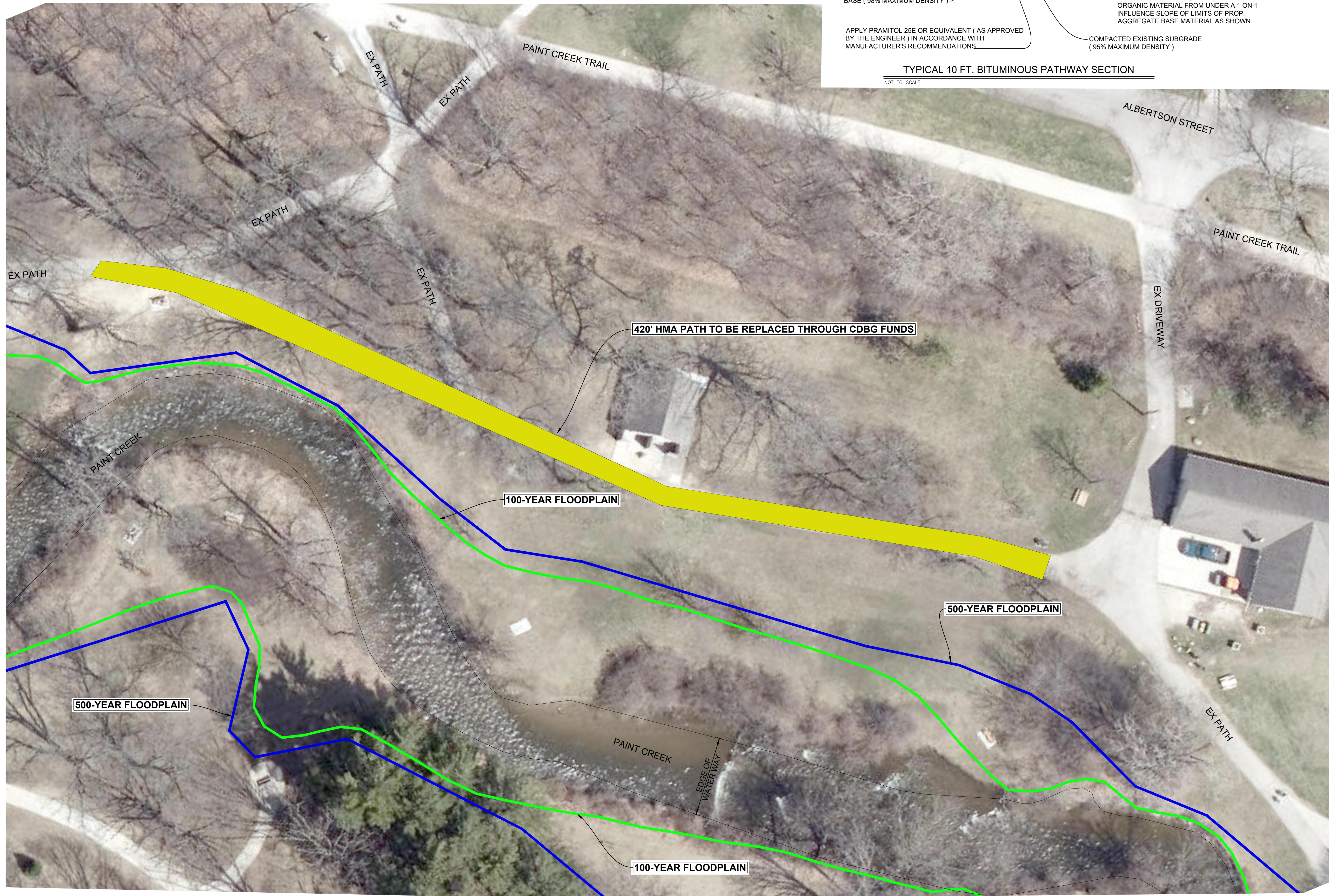
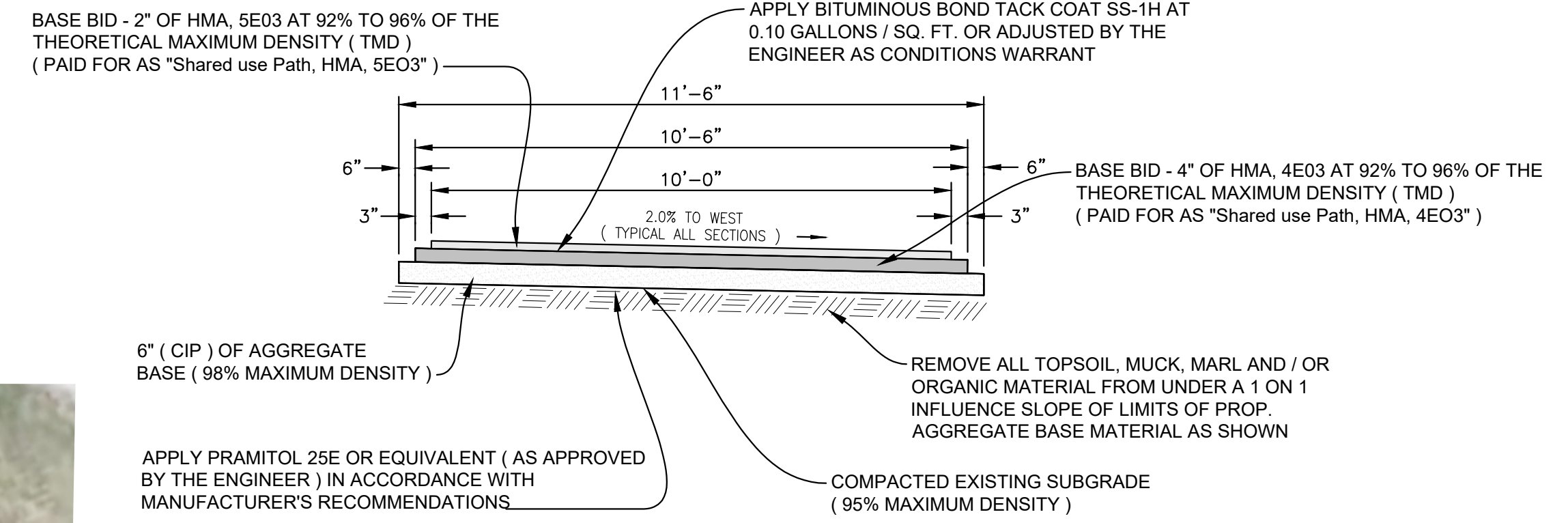
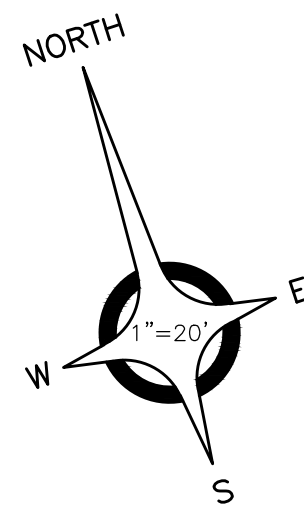

ANDERSON, ECKSTEIN & WESTRICK, INC.
 CIVIL ENGINEERS - SURVEYORS - ARCHITECTS

51301 Schoenherr Road
 Shelby Township, MI 48315
 586.726.1234 | aewinc.com

Engineering Strong Communities

DATE	SUBMITTALS/REVISIONS

PROJECT NAME:

**CITY OF ROCHESTER
 MUNICIPAL PARK
 PATH**

SHEET TITLE:

**CDBG PATH
 REPLACEMENT**

Original Scope of Work

CLIENT:
 CITY OF ROCHESTER

<input checked="" type="checkbox"/> PRELIMINARY	<input type="checkbox"/> CONSTRUCTION	<input type="checkbox"/> RECORD
DRAWN BY: KA	CHECKED BY: JMR	DATE: JULY 2024
SCALE: 1" = 20' HORIZ.		
0 10 20 40		

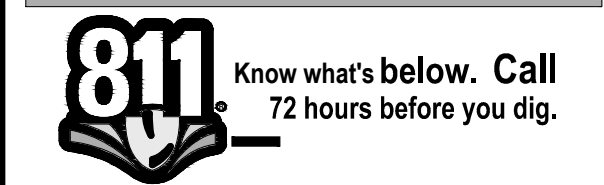

UTILITY INFORMATION, AS SHOWN, INDICATES APPROXIMATE LOCATIONS AND TYPES OF EXISTING FACILITIES ONLY, AS DISCLOSED BY RECORDS PROVIDED TO THIS FIRM FROM THE VARIOUS UTILITY COMPANIES. NO GUARANTEE IS GIVEN OR IMPLIED AS TO THE COMPLETENESS OR ACCURACY THEREOF.

PRIOR TO CONSTRUCTION, ALL LOCATIONS AND DEPTHS OF EXISTING OVERHEAD AND UNDERGROUND UTILITIES (IN CONFLICT WITH THE CONSTRUCTION OF THESE PROPOSED IMPROVEMENTS) SHALL BE VERIFIED IN THE FIELD. DURING THE CONSTRUCTION, THE CONTRACTOR SHALL PROTECT AND SUPPORT ALL UTILITIES THAT ARE ENCOUNTERED. (ALL COSTS FOR UTILITY LOCATION VERIFICATION, SUPPORT AND PROTECTION SHALL BE INCLUDED IN THE PROPOSED PAY ITEM CONFLICTING WITH THAT UTILITY).

DURING CONSTRUCTION, THE CONTRACTOR SHALL USE EXTREME CAUTION WHEN OPERATING NEAR ANY AND ALL OVERHEAD AND / OR BURIED UTILITIES.

PROJECT NO.
 0270-0205

M:\0270\0205\CADD\DRAWINGS\CONSTRUCTION\CIVIL\MUNICIPAL PARK PATH\PHASE 3.DWG
 01_AERIAL-8/26/2024 2:11:57 PM

SHEET NO.

City of Rochester



CDBG PATH REPLACEMENT

Additional Scope of Work

CAUTION

THIS MAP IS INTENDED FOR REFERENCE PURPOSES ONLY. ANDERSON, ECKSTEIN & WESTRICK, INC. AND THE CITY OF ROCHESTER DO NOT GUARANTEE THE ACCURACY OF THIS INFORMATION AND DISCLAIMS ALL LIABILITY FROM ALL CLAIMS, SUITS, DEMANDS AND JUDGEMENTS ARISING FROM THE USE OF THIS INFORMATION.



LEGEND

- Path Replacement Location
- 100 Year Floodplain
- Floodway

DATE PRINTED: November 15, 2024	DATE CREATED: November 15, 2024
SCALE: 1" = 70'	MAP DOCUMENT: HMA Path.aprx
PROJECT NO: 0270-0205	CREATED BY: JMM CHECKED BY: AAP



ROCHESTER POLICE DEPARTMENT

400 SIXTH STREET
ROCHESTER, MICHIGAN 48307
PHONE (248) 651-9621
FAX (248) 651-3607
<http://www.rochestermi.org>

GEORGE T. ROUHIB JR.
CHIEF OF POLICE

MEMORANDUM

Date: April 22, 2025
To: Nik Banda, City Manager
From: George T. Rouhib Jr., Chief of Police
Subject: Patrol Vehicle Purchase-Council Agenda

Issue: Request to approve the purchase of a 2025 Chevrolet Tahoe for Road Patrol

Analysis: The police department is requesting to purchase a 2025 Chevy Tahoe (police package) for road patrol in accordance with the Revolving Equipment Fund Schedule. The vehicle will be purchased from Berger Chevrolet, 2515 28th Street S.E., Grand Rapids, Michigan 49152 for \$53,984.00. Berger Chevrolet is part of the County Bid and offers patrol vehicles at governmental pricing. The new patrol vehicle will replace a 2019 Ford Explorer which will be sold at a later date. The price does not include changing over equipment and/or purchasing new emergency lights. This purchase was discussed with the Finance Director.

Requested Action: Review and approve request as presented.

Attachment(s): Bid Specifications Sheet

BID PER ENCLOSED SPECIFICATIONS

Cost per vehicle \$53,984.00

Number of units 1

\$53,984.00

Vehicle Description:

Year 2025

Make Chevrolet

Model Tahoe 4wd
police package
Berger 11

Vendor:

Berger Chevrolet Inc.

Address 2525 28th Street S.E.

Grand Rapids, MI 49512

Phone (616) 575-9629

Fax (616) 988-9178

Bid Prepared For :

City of Rochester

Price includes title fee and delivery. Price based on
Municipal discount in the State of Michigan.

Signature *Robert Evans*

Printed Signature Robert M. Evans

Date 4/15/2025



Berger Chevrolet Inc

Robert Evans | 6162925749 | bevans@bergerchevy.com

Berger 11 2025 Chevrolet Tahoe (CK10706) 4WD 4dr Commercial (Complete)

Selected Model and Options

MODEL

CODE	MODEL
CK10706	2025 Chevrolet Tahoe 4WD 4dr Commercial

COLORS

CODE	DESCRIPTION
GBA	Black

OPTIONS

(† Denotes a Custom Equipment Option)

CODE	DESCRIPTION
—	Active Hill Hold Assist (Included and only available with (9C1) Police Vehicle or (5W4) Special Service Vehicle.)
—	Seat belts, 3-point, all seating positions (Included and only available with (9C1) Police Vehicle or (5W4) Special Service Vehicle.)
—	Capless Fuel Fill (Included and only available with (9C1) Police Vehicle or (5W4) Special Service Vehicle.)
—	Protected idle allows vehicle engine to remain idling and vehicle immobilized while FOB is outside vehicle (Included and only available (9C1) Police Vehicle or (5W4) Special Service Vehicle.)
—	Instrumentation, analog with certified 140 mph speedometer, odometer with trip odometer, engine hour meter, fuel level, voltmeter, engine temperature, oil pressure and tachometer (Included and only available with (9C1) Police Vehicle or (5W4) Special Service Vehicle.)
—	Exterior ornamentation delete (front & rear Chevrolet bowties will remain) (Included and only available with (9C1) Police Vehicle or (5W4) Special Service Vehicle.)
—	Power supply, 100-amp, auxiliary battery, passenger compartment wiring harness (Included and only available with (9C1) Police Vehicle or (5W4) Special Service Vehicle.)
—	Power supply, 120-amp, (4) 30-amp circuit, Primary battery, relay controlled, passenger compartment harness wiring (Included and only available with (9C1) Police Vehicle or (5W4) Special Service Vehicle.)
—	Power supply, 50-amp, power supply, auxiliary battery, passenger compartment wiring harness (Included and only available with (9C1) Police Vehicle or (5W4) Special Service Vehicle.)
—	Theft-deterrent system, vehicle, PASS-Key III (Included and only available with (9C1) Police Vehicle or (5W4) Special Service Vehicle.)
001†	LED spotlights†
1FL	Commercial Preferred Equipment Group includes standard equipment
5J3	Calibration, Surveillance Mode interior lighting (Included and only available with (9C1) Police Vehicle or (5W4) Special Service Vehicle.)
5J9	Calibration, taillamp flasher, Red/White (Included and only available with (9C1) Police Vehicle or (5W4) Special Service Vehicle.)

At the user's request, prices for this vehicle have been formulated on the basis of Initial Pricing for the vehicle, however GM cannot guarantee that Initial Pricing is available. This document contains information considered Confidential between GM and its Clients uniquely. The information provided is not intended for public disclosure. Prices, specifications, and availability are subject to change without notice, and do not include certain fees, taxes and charges that may be required by law or vary by manufacturer or region. Performance figures are guidelines only, and actual performance may vary. Photos may not represent actual vehicles or exact configurations. Content based on report preparer's input is subject to the accuracy of the input provided.
 Data Version: 25217. Data Updated: Apr 14, 2025 6:44:00 PM PDT.



Berger Chevrolet Inc

Robert Evans | 6162925749 | bevans@bergerchevy.com

Berger 11 2025 Chevrolet Tahoe (CK10706) 4WD 4dr Commercial (✔ Complete)

OPTIONS

(† Denotes a Custom Equipment Option)

CODE	DESCRIPTION
5LO	Calibration, taillamp flasher, Red/Red (Included and only available with (9C1) Police Vehicle or (5W4) Special Service Vehicle.)
5T5	Seats, front cloth and second row vinyl (Requires (9C1) Police Vehicle or (5W4) Special Service Vehicle. On 4WD model, not available with (A50) front bucket seats.)
6C7	Lighting, red and white front auxiliary dome Red and white LED auxiliary dome lamp is located on headliner between front row seats. The auxiliary lamp is wired independently from standard dome lamp (Requires (9C1) Police Vehicle or (5W4) Special Service Vehicle.)
6E2	Fleet Calibration provides a single key with a specific code that is common to the door locks of all the vehicles in the vehicle fleet. Key code is an alternate to SEO (6E8) complete vehicle fleet common key. NOTE: NOT COMPATIBLE with previous model years (Requires (AMF) Remote Keyless Entry Package. Includes (AU7) fleet common key with (9C1) Police Vehicle or (5W4) Special Service Vehicle. Not available with SEO (6E8) Fleet Calibration.)
6J3	Wiring, grille lamps and siren speakers (Requires (9C1) Police Vehicle or (5W4) Special Service Vehicle.)
6J7	Flasher system, headlamp and taillamp, DRL compatible with control wire (Included and only available with (9C1) Police Vehicle or (5W4) Special Service Vehicle.)
6N5	Switches, rear window inoperative (rear windows can only operate from driver's position.) (Requires (9C1) Police Vehicle or (5W4) Special Service Vehicle.)
6N6	Door locks and handles, inside rear doors inoperative (door can only be opened from outside) (Requires (9C1) Police Vehicle or (5W4) Special Service Vehicle.)
7X3	Spotlamp, left-hand (Requires (9C1) Police Vehicle or (5W4) Special Service Vehicle. Not available with SEO (7X2) left and right-hand spotlamps.)
9C1	Identifier for Police Package Vehicle includes, (K47) heavy-duty air filter, (KX4) 250 amp high output alternator, (K6K) 760 cold-cranking amps auxiliary battery, electrical power & vehicle signals for customer connection located at the center front floor. Auxiliary battery circuit for customer connection located in the rear cargo area, (Z56) heavy-duty, police-rated suspension, (XCS) 275/55R20SL all-season tires, (RAV) 275/55R20 all-season spare tire, Police brakes, (RC1) front skid plate, (PXT) 20" steel wheels, Certified speedometer, SEO (5J3) Surveillance Mode interior lighting calibration, SEO (UT7) blunt cut cargo area and blunt cut console area ground wires, (V53) delete luggage rack side rails and (ATD) third row seat delete) (Also includes (NP0) active single-speed transfer case.) *Upon selection of this option the base price will change*
9G8	Headlamps, Daytime Running Lamps and automatic headlamp control delete (Requires (9C1) Police Vehicle or (5W4) Special Service Vehicle.)
AMF	Remote Keyless Entry Package includes 4 additional transmitters, NOTE: programming of remotes is at customer's expense. Programming remotes is not a warranty expense (Included and only available with (9C1) Police Vehicle or (5W4) Special Service Vehicle.)
ATD	Seat delete, third row (Included and only available with (9C1) Police Package or (5W4) Special Service Package.)
AU7	Key common, fleet (Included and only available with SEO (6E2) Fleet Calibration or SEO (6E8) Fleet Calibration and requires (9C1) Police Vehicle or (5W4) Special Service Vehicle.)

IP At the user's request, prices for this vehicle have been formulated on the basis of Initial Pricing for the vehicle, however GM cannot guarantee that Initial Pricing is available. This document contains information considered Confidential between GM and its Clients uniquely. The information provided is not intended for public disclosure. Prices, specifications, and availability are subject to change without notice, and do not include certain fees, taxes and charges that may be required by law or vary by manufacturer or region. Performance figures are guidelines only, and actual performance may vary. Photos may not represent actual vehicles or exact configurations. Content based on report preparer's input is subject to the accuracy of the input provided.
 Data Version: 25217. Data Updated: Apr 14, 2025 6:44:00 PM PDT.



Berger Chevrolet Inc

Robert Evans | 6162925749 | bevans@bergerchevy.com

Berger 11 2025 Chevrolet Tahoe (CK10706) 4WD 4dr Commercial (✔ Complete)

OPTIONS

(† Denotes a Custom Equipment Option)

CODE	DESCRIPTION
AYH	Airbags, Frontal airbags for driver and front outboard passenger; Seat-mounted side-impact airbags for driver and front outboard passenger; Head-curtain airbags for all rows in outboard seating positions (Included and only available with (9C1) Police Vehicle or (5W4) Special Services Vehicle.)
AZ3	Seats, front 40/20/40 split-bench (Included and only available with (9C1) Police Vehicle and (5W4) Special Service Vehicle.)
BCV	Lock control, driver side auto door lock disable (Included and only available with (9C1) Police Vehicle or (5W4) Special Service Vehicle.)
BTV	Remote start (Included and only available with (9C1) Police Vehicle or (5W4) Special Service Vehicle.)
C6G	GVWR, 7600 lbs. (3447 kg) (4WD models only.) (STD)
CTB	Intersection Automatic Emergency Braking intersection alert, braking (Requires (9C1) Police Vehicle or (5W4) Special Service Vehicle. Included and only available with (PQA) 1FL Safety Package.)
DRZ	Rear Camera Mirror, inside rearview auto-dimming with full camera display (Included with (PQA) 1FL Safety Package when ordered with (9C1) Police Package. When (PQA) 1FL Safety Package is not ordered, requires (UE1) OnStar and (AZ3) 40/20/40 split-bench seat.)
FE9	Emissions, Federal requirements
GBA	Black
GU5	Rear axle, 3.23 ratio
H1T	Jet Black, Cloth seat trim (Requires (9C1) Police Vehicle or (5W4) Special Service Vehicle.)
K34	Cruise control, electronic with set and resume speed (Included and only available with (9C1) Police Vehicle or (5W4) Special Service Vehicle.)
K3W	Battery, 850 cold-cranking amps with 95 amp hour rating (Included and only available with (9C1) Police Vehicle or (5W4) Special Service Vehicle.)
K6K	Battery, auxiliary, 760 cold-cranking amps with 70 amp hour rating (packaged behind left rear cargo area panel) (Included and only available with (9C1) Police Vehicle or (5W4) Special Service Vehicle.)
KX4	Alternator, 250 amps (Included and only available with (9C1) Police Vehicle or (5W4) Special Service Vehicle.)
L84	Engine, 5.3L EcoTec3 V8 with Dynamic Fuel Management, Direct Injection and Variable Valve Timing, includes aluminum block construction (355 hp [265 kW] @ 5600 rpm, 383 lb-ft of torque [518 Nm] @ 4100 rpm) (STD)
MHU	Transmission, 10-speed automatic electronically controlled with overdrive, includes Traction Select System including tow/haul (Included and only available with (9C1) Police Vehicle or (5W4) Special Service Vehicle.)
PXT	Wheels, 20" x 9" (50.8 cm x 22.9 cm) steel (Included and only available with (9C1) Police Vehicle.)
RAV	Tire, spare 275/55R20 all-season, blackwall, Firestone Firehawk Pursuit (Included and only available with (9C1) Police Vehicle.)
RC1	Skid plate, front (Included and only available with (9C1) Police Vehicle or (5W4) Special Service Vehicle.)

IP At the user's request, prices for this vehicle have been formulated on the basis of Initial Pricing for the vehicle, however GM cannot guarantee that Initial Pricing is available. This document contains information considered Confidential between GM and its Clients uniquely. The information provided is not intended for public disclosure. Prices, specifications, and availability are subject to change without notice, and do not include certain fees, taxes and charges that may be required by law or vary by manufacturer or region. Performance figures are guidelines only, and actual performance may vary. Photos may not represent actual vehicles or exact configurations. Content based on report preparer's input is subject to the accuracy of the input provided.
 Data Version: 25217. Data Updated: Apr 14, 2025 6:44:00 PM PDT.



Berger Chevrolet Inc

Robert Evans | 6162925749 | bevans@bergerchevy.com

Berger 11 2025 Chevrolet Tahoe (CK10706) 4WD 4dr Commercial (✔ Complete)

OPTIONS

(† Denotes a Custom Equipment Option)

CODE	DESCRIPTION
RNQ	Wheel, full-size spare, matching 20" (50.8 cm) steel wheel without center cap (Included and only available with (9C1) Police Vehicle.)
T53	Lamps, alternate flashing Red & Blue rear compartment lid warning (visible when liftgate is open) and controlled by momentary liftgate mounted switch or ground wire (Requires (9C1) Police Vehicle or (5W4) Special Service Vehicle.)
T66	Wiring provision, for outside mirrors and cargo side mirrors (Included and only available with (9C1) Police Vehicle or (5W4) Special Service Vehicle.)
TQ5	IntelliBeam, automatic high beam on/off (When ordered with (9C1) Police Vehicle or (5W4) Special Service Vehicle, included and only available with (PQA) 1FL Safety Package.)
UD7	Rear Parking Assist (Included and only available with (9C1) Police Vehicle and (5W4) Special Service Vehicle.)
UEU	Forward Collision Alert (When ordered with (9C1) Police Vehicle or (5W4) Special Service Vehicle, included and only available with (PQA) 1FL Safety Package.)
UFB	Rear Cross Traffic Braking (Included and only available with (PQA) 1FL Safety Package when ordered with (9C1) Police Vehicle or (5W4) Special Service Vehicle.)
UHY	Automatic Emergency Braking (When ordered with (9C1) Police Vehicle or (5W4) Special Service Vehicle, included and only available with (PQA) 1FL Safety Package.)
UKI	Blind Zone Steering Assist (Requires (9C1) Police Vehicle or (5W4) Special Service Vehicle. Included and only available with (PQA) 1FL Safety Package.)
UKM	Lane Keep Assist with Lane Departure Warning, enhanced (Included and only available with (PQA) 1FL Safety Package when ordered with (9C1) Police Vehicle or (5W4) Special Service Vehicle.)
UKT	Front Pedestrian and Bicyclist Braking (Included and only available with (PQA) 1FL Safety Package when ordered with (9C1) Police Vehicle.)
UOW	Side Bicyclist Alert (Included and only available with (PQA) 1FL Safety Package when ordered with (9C1) Police Vehicle or (5W4) Special Service Vehicle.)
URW	Audio system, 17.7" diagonal advanced color LCD display with Google built-in compatibility (select service plan required, terms and limitations apply), including navigation capability, connected apps, personalized profiles for each driver's settings, Natural Voice Recognition and Phone Integration (STD)
UT7	Ground wires, blunt cut cargo area and blunt cut console area (Included and only available with (9C1) Police Vehicle or (5W4) Special Service Vehicle.)
UTQ	Theft-deterrent system content, disable, the alarm and horn become non-functional in an attempt of theft to the vehicle (Requires (9C1) Police Vehicle or (5W4) Special Service Vehicle.)
V53	Luggage rack side rails, delete (Included and only available with (9C1) Police Vehicle or (5W4) Special Service Package.)
V76	Recovery hooks, 2 front, frame-mounted, Black (Requires (9C1) Police Vehicle or (5W4) Special Service Vehicle. Required on all models going to Alaska, Guam, Hawaii, Puerto Rico and Virgin Islands. All Tahoe (9C1) and (5W4) vehicles include front fascia with recovery hook openings.)

IP At the user's request, prices for this vehicle have been formulated on the basis of Initial Pricing for the vehicle, however GM cannot guarantee that Initial Pricing is available. This document contains information considered Confidential between GM and its Clients uniquely. The information provided is not intended for public disclosure. Prices, specifications, and availability are subject to change without notice, and do not include certain fees, taxes and charges that may be required by law or vary by manufacturer or region. Performance figures are guidelines only, and actual performance may vary. Photos may not represent actual vehicles or exact configurations. Content based on report preparer's input is subject to the accuracy of the input provided.

Data Version: 25217. Data Updated: Apr 14, 2025 6:44:00 PM PDT.



Berger Chevrolet Inc

Robert Evans | 6162925749 | bevans@bergerchevy.com

Berger 11 2025 Chevrolet Tahoe (CK10706) 4WD 4dr Commercial (✔ Complete)

OPTIONS

(† Denotes a Custom Equipment Option)

CODE	DESCRIPTION
VPV	Ship Thru, Produced in Arlington Assembly and shipped to Kerr Industries and onto Arlington Assembly (Included with SEO (6J8) White Left/White Right Whelen LED Lamp Package, SEO (6J9) Red Left/Red Right Whelen LED Lamp Package, SEO (6JE) Blue Left/Blue Right Whelen LED Lamp Package, SEO (6JG) Red Left/Blue Right Whelen LED Lamp Package, SEO (6C7) red and white front auxiliary dome lighting, SEO (6N6) door locks and handles, SEO (7X2) left- and right-hand spotlamps, SEO (7X3) left-hand spotlight, SEO (T53) alternate flashing Red & Blue rear compartment lid warning lamps, SEO (UN9) Radio Suppression Package, SEO (6J3) grille lamps and siren speakers wiring, SEO (6J4) horn and siren circuit wiring and SEO (WX7) auxiliary speaker wiring.)
VZ2	Speedometer calibration (Included and only available with (9C1) Police Vehicle or (5W4) Special Service Vehicle.)
WUA	Fascia, front high-approach angle (Included and only available with (9C1) Police Vehicle or (5W4) Special Service Vehicle.)
XCS	Tires, 275/55R20SL all-season, blackwall, Firestone Firehawk Pursuit (Included and only available with (9C1) Police Vehicle.)
Z56	Suspension Package, heavy-duty, police-rated. Full independent suspension with monotube dampers, linear coil springs, 35mm solid front stabilizer bar and 32mm hollow rear stabilizer bar (Included and only available with (9C1) Police Vehicle.)

Options Total

At the user's request, prices for this vehicle have been formulated on the basis of Initial Pricing for the vehicle, however GM cannot guarantee that Initial Pricing is available. This document contains information considered Confidential between GM and its Clients uniquely. The information provided is not intended for public disclosure. Prices, specifications, and availability are subject to change without notice, and do not include certain fees, taxes and charges that may be required by law or vary by manufacturer or region. Performance figures are guidelines only, and actual performance may vary. Photos may not represent actual vehicles or exact configurations. Content based on report preparer's input is subject to the accuracy of the input provided.
Data Version: 25217. Data Updated: Apr 14, 2025 6:44:00 PM PDT.



Berger Chevrolet Inc

Robert Evans | 6162925749 | bevans@bergerchevy.com

Berger 11 2025 Chevrolet Tahoe (CK10706) 4WD 4dr Commercial (✔ Complete)

Standard Equipment

Mechanical

Engine, 5.3L EcoTec3 V8 with Dynamic Fuel Management, Direct Injection and Variable Valve Timing, includes aluminum block construction (355 hp [265 kW] @ 5600 rpm, 383 lb-ft of torque [518 Nm] @ 4100 rpm) (STD)

Transmission, 10-speed automatic electronically controlled with overdrive, includes Traction Select System including tow/haul (STD)

Rear axle, 3.23 ratio

Suspension, Premium Smooth Ride

GVWR, 7600 lbs. (3447 kg) (4WD models only.) (STD)

Keyless start, push button

Automatic Stop/Start (Not available when (9C1) Police Vehicle or (5W4) Special Service Vehicle is ordered.)

Engine control, stop/start system disable button, non-latching (Not available when (9C1) Police Vehicle or (5W4) Special Service Vehicle is ordered.)

Engine air filtration monitor

Fuel, gasoline, E15

Transfer case, active, single-speed, electronic Autotrac does not include neutral. Cannot be dinghy towed

Differential, mechanical limited-slip

4-wheel drive

Air filter, heavy-duty

Cooling, external engine oil cooler, heavy-duty air-to-oil integral to driver side of radiator

Cooling, auxiliary transmission oil cooler, heavy-duty air-to-oil

Alternator, 220 amps (Not available with (9C1) Police Vehicle or (5W4) Special Service Vehicle.)

Trailer equipment includes trailering hitch platform, 7-wire harness with independent fused trailering circuits mated to a 7-way connector and 2" trailering receiver

Trailer sway control

Hitch Guidance

Suspension, front coil-over-shock with stabilizer bar

Suspension, rear multi-link with coil springs

Steering, power

Brakes, 4-wheel antilock, 4-wheel disc with DURALIFE rotors

Exhaust, single system, single-outlet

Mechanical Jack with tools

IP At the user's request, prices for this vehicle have been formulated on the basis of Initial Pricing for the vehicle, however GM cannot guarantee that Initial Pricing is available. This document contains information considered Confidential between GM and its Clients uniquely. The information provided is not intended for public disclosure. Prices, specifications, and availability are subject to change without notice, and do not include certain fees, taxes and charges that may be required by law or vary by manufacturer or region. Performance figures are guidelines only, and actual performance may vary. Photos may not represent actual vehicles or exact configurations. Content based on report preparer's input is subject to the accuracy of the input provided.
Data Version: 25217. Data Updated: Apr 14, 2025 6:44:00 PM PDT.



Berger Chevrolet Inc

Robert Evans | 6162925749 | bevans@bergerchevy.com

Berger 11 2025 Chevrolet Tahoe (CK10706) 4WD 4dr Commercial (✔ Complete)

Exterior

- Wheels, 18" x 8.5" (45.7 cm x 21.6 cm) Bright Silver painted aluminum (STD)
- Tires, 265/65R18SL all-season, blackwall (Standard with (RCV) 18" Bright Silver painted aluminum wheels only.) (STD)
- Wheel, full-size spare, 17" (43.2 cm) steel
- Tire, spare P265/70R17 all-season, blackwall
- Tire carrier, lockable outside spare, winch-type mounted under frame at rear
- Active aero shutters, upper
- Fascia, front
- Luggage rack side rails, roof-mounted, Black, standard (Available with (5W4) Special Services Vehicle.)
- Assist steps, Black with chrome accent strip
- Headlamps, LED
- Tail lamps, LED
- Mirrors, outside heated power-adjustable, manual-folding, body-color
- Mirror caps, body-color
- Glass, deep-tinted (all windows, except light-tinted glass on windshield and driver- and front passenger-side glass)
- Glass, acoustic, laminated
- Glass, windshield shade band
- Windshield, solar absorbing
- Wipers, front intermittent, Rainsense
- Wiper, rear intermittent with washer
- Door handles, body-color
- Liftgate, rear manual

Entertainment

- Audio system, 17.7" diagonal advanced color LCD display with Google built-in compatibility (select service plan required, terms and limitations apply), including navigation capability, connected apps, personalized profiles for each driver's settings, Natural Voice Recognition and Phone Integration (STD)
- Audio system feature, 6-speaker system
- Bluetooth for phone personal cell phone connectivity to vehicle audio system
- 5G Wi-Fi Hotspot capable (Requires (UE1) OnStar. Terms and limitations apply. See onstar.com or dealer for details.)

IP At the user's request, prices for this vehicle have been formulated on the basis of Initial Pricing for the vehicle, however GM cannot guarantee that Initial Pricing is available. This document contains information considered Confidential between GM and its Clients uniquely. The information provided is not intended for public disclosure. Prices, specifications, and availability are subject to change without notice, and do not include certain fees, taxes and charges that may be required by law or vary by manufacturer or region. Performance figures are guidelines only, and actual performance may vary. Photos may not represent actual vehicles or exact configurations. Content based on report preparer's input is subject to the accuracy of the input provided.
 Data Version: 25217. Data Updated: Apr 14, 2025 6:44:00 PM PDT.



Berger Chevrolet Inc

Robert Evans | 6162925749 | bevans@bergerchevy.com

Berger 11 2025 Chevrolet Tahoe (CK10706) 4WD 4dr Commercial (Complete)

Entertainment

Wi-Fi Hotspot capable (Requires (UE1) OnStar. Terms and limitations apply. See onstar.com or dealer for details.)

SiriusXM, delete

Wireless Apple CarPlay/Wireless Android Auto

Interior

Seats, front bucket (4WD only. When ordered with (9C1) Police Vehicle, requires (PQA) 1FL Safety Package and (UDA) OnStar deactivated. Includes (D07) floor console. Not available with SEO (5Y1) front center seat delete or SEO (5T5) front cloth and second row vinyl seats.)

Seat adjuster, driver 8-way power

Seat adjuster, front passenger 6-way power

Seat adjuster, front passenger 8-way power

Seat adjuster, driver 2-way power lumbar

Seat adjuster, front passenger 2-way power lumbar

Seats, second row 60/40 split-folding bench, manual

Seats, third row 60/40 split-folding bench, manual (Not available with (9C1) Police Package or (5W4) Special Service Package.)

Floor covering, Black rubberized vinyl (Deleted when (B30) floor covering is ordered.)

Electronic Precision Shift

Steering column lock, electrical

Steering column, manual tilt and telescopic

Steering wheel, vinyl

Steering wheel controls, mounted audio, Driver Information Center, Adaptive Cruise Control, Forward Collision Alert following gap button and heated steering wheel (when equipped)

Driver Information Center, 11" diagonal multi-color digital display

Door locks, power programmable with lockout protection and delayed locking

Keyless Open includes extended range Remote Keyless Entry

Window, power with driver Express-Up/Down

Window, power with front passenger Express-Up/Down

Windows, power with rear Express-Down

Adaptive Cruise Control (Not available with (9C1) Police Vehicle or (5W4) Special Service Vehicle.)

Universal Vehicle Module

At the user's request, prices for this vehicle have been formulated on the basis of Initial Pricing for the vehicle, however GM cannot guarantee that Initial Pricing is available. This document contains information considered Confidential between GM and its Clients uniquely. The information provided is not intended for public disclosure. Prices, specifications, and availability are subject to change without notice, and do not include certain fees, taxes and charges that may be required by law or vary by manufacturer or region. Performance figures are guidelines only, and actual performance may vary. Photos may not represent actual vehicles or exact configurations. Content based on report preparer's input is subject to the accuracy of the input provided.
Data Version: 25217. Data Updated: Apr 14, 2025 6:44:00 PM PDT.



Berger Chevrolet Inc

Robert Evans | 6162925749 | bevens@bergerchevy.com

Berger 11 2025 Chevrolet Tahoe (CK10706) 4WD 4dr Commercial (✔ Complete)

Interior

Theft-deterrent system, electrical, unauthorized entry

Display, automatic occupant sensing (Requires (9C1) Police Vehicle or (5W4) Special Service Vehicle.)

Wireless Phone Charging, for portable devices

USB ports, 2 type-A and C, charge and data, located on front console

USB ports, 2 type-C, charge-only, located in third row

Air conditioning, tri-zone automatic climate control with individual climate settings for driver, right front passenger and rear seat occupants

Air conditioning, rear

Defogger, rear-window electric

Power outlets, 2, 120-volt, located on the rear of the center console and rear cargo area

Sill plates, bright, front and rear door

Mirror, inside rearview manual day/night

Visors, driver and front passenger illuminated vanity mirrors, sliding

Assist handles, overhead, driver and front passenger, located in headliner

Assist handles, front passenger A-pillar and second row outboard B-pillar

Lighting, interior with dome light, driver- and passenger-side door switch with delayed entry feature, cargo lights, door handle or Remote Keyless Entry-activated illuminated entry and map lights in front and second seat positions

Cargo management system

Chevrolet Connected Access capable (Subject to terms. See onstar.com or dealer for details.)

Safety-Interior

Forward Collision Alert (Deleted when (9C1) Police Vehicle or (5W4) Special Service Vehicle is ordered.)

Airbags, Frontal airbags for driver and front outboard passenger; Seat-mounted side-impact airbags for driver and front outboard passenger; Driver inboard seat-mounted side-impact airbag; Head-curtain airbags for all rows in outboard seating positions (Always use seat belts and child restraints. Children are safer when properly secured in a rear seat in the appropriate child restraint. See the Owner's Manual for more information.)

Front outboard Passenger Sensing System for frontal outboard passenger airbag (Always use seat belts and child restraints. Children are safer when properly secured in a rear seat in the appropriate child restraint. See the Owner's Manual for more information.)

Hill Start Assist

OnStar Services capable (On 4WD model, deleted when (UDA) OnStar deactivated is ordered. See onstar.com for details and limitations. Services vary by model. Service plan required.)

Enhanced Automatic Parking Assist (Not available with (9C1) Police Vehicle or (5W4) Special Service Vehicle.)

IP At the user's request, prices for this vehicle have been formulated on the basis of Initial Pricing for the vehicle, however GM cannot guarantee that Initial Pricing is available. This document contains information considered Confidential between GM and its Clients uniquely. The information provided is not intended for public disclosure. Prices, specifications, and availability are subject to change without notice, and do not include certain fees, taxes and charges that may be required by law or vary by manufacturer or region. Performance figures are guidelines only, and actual performance may vary. Photos may not represent actual vehicles or exact configurations. Content based on report preparer's input is subject to the accuracy of the input provided.

Data Version: 25217. Data Updated: Apr 14, 2025 6:44:00 PM PDT.



Berger Chevrolet Inc

Robert Evans | 6162925749 | bevans@bergerchevy.com

Berger 11 2025 Chevrolet Tahoe (CK10706) 4WD 4dr Commercial (✔ Complete)

Safety-Interior

HD Surround Vision

Rear Camera Washer

Rear Pedestrian Alert

Forward Collision Alert (Deleted when (9C1) Police Vehicle or (5W4) Special Service Vehicle is ordered.)

Safety Alert Seat

Rear Seat Reminder

Buckle to Drive prevents vehicle from being shifted out of Park until driver seat belt is fastened; times out after 20 seconds and encourages seat belt use, can be turned on and off in Settings or Teen Driver menu (Defaulted off. Feature can be turned on in the infotainment menu.)

Door locks, rear child security, manual

LATCH system (Lower Anchors and Tethers for CHildren), for child restraint seats lower anchors and top tethers located in all second-row seating positions, top tethers located in third row seating positions

Teen Driver a configurable feature that lets you activate customizable vehicle settings associated with a key fob, to help encourage safe driving behavior. It can limit certain available vehicle features, and it prevents certain safety systems from being turned off. An in-vehicle report card gives you information on driving habits and helps you to continue to coach your new driver

Tire Pressure Monitoring System auto learn, includes Tire Fill Alert (does not apply to spare tire)

Warning tones headlamp on, driver and right-front passenger seat belt unfasten and turn signal on

OnStar Basics (OnStar Fleet Basics for Fleet) Drive confidently with core OnStar services including remote commands, built-in voice assistance, real-time traffic and navigation, and Automatic Crash Response to help if you're in need. (OnStar Basics includes remote commands, Navigation, Voice Assistance, and Automatic Crash Response, for eligible vehicles with compatible software. For MY25 vehicles, OnStar Basics is standard for 8 years; OnStar plan, working electrical system, cell reception and GPS signal required. OnStar links to emergency services. Service coverage varies with conditions and location. Service availability, features and functionality vary by device and software version. See onstar.com for details and limitations.)

Safety-Mechanical

Enhanced Automatic Emergency Braking

Reverse Automatic Braking (Not available with (9C1) Police Vehicle or (5W4) Special Service Vehicle.)

StabiliTrak, stability control system with brake assist, includes traction control

IP At the user's request, prices for this vehicle have been formulated on the basis of Initial Pricing for the vehicle, however GM cannot guarantee that Initial Pricing is available. This document contains information considered Confidential between GM and its Clients uniquely. The information provided is not intended for public disclosure. Prices, specifications, and availability are subject to change without notice, and do not include certain fees, taxes and charges that may be required by law or vary by manufacturer or region. Performance figures are guidelines only, and actual performance may vary. Photos may not represent actual vehicles or exact configurations. Content based on report preparer's input is subject to the accuracy of the input provided.
Data Version: 25217. Data Updated: Apr 14, 2025 6:44:00 PM PDT.



Berger Chevrolet Inc

Robert Evans | 6162925749 | bevans@bergerchevy.com

Berger 11 2025 Chevrolet Tahoe (CK10706) 4WD 4dr Commercial (Complete)

WARRANTY

Warranty Note: <<< Preliminary 2025 Warranty >>>

Basic Years: 3

Basic Miles/km: 36,000

Drivetrain Years: 5

Drivetrain Miles/km: 60,000

Drivetrain Note: 3.0L & 6.0L Duramax® Turbo-Diesel engines, and certain commercial, government, and qualified fleet vehicles: 5 years/100,000 miles

Corrosion Years (Rust-Through): 6

Corrosion Years: 3

Corrosion Miles/km (Rust-Through): 100,000

Corrosion Miles/km: 36,000

Roadside Assistance Years: 5

Roadside Assistance Miles/km: 60,000

Roadside Assistance Note: 3.0L & 6.0L Duramax® Turbo-Diesel engines, and certain commercial, government, and qualified fleet vehicles: 5 years/100,000 miles

Maintenance Note: First Visit: 12 Months/12,000 Miles

At the user's request, prices for this vehicle have been formulated on the basis of Initial Pricing for the vehicle, however GM cannot guarantee that Initial Pricing is available. This document contains information considered Confidential between GM and its Clients uniquely. The information provided is not intended for public disclosure. Prices, specifications, and availability are subject to change without notice, and do not include certain fees, taxes and charges that may be required by law or vary by manufacturer or region. Performance figures are guidelines only, and actual performance may vary. Photos may not represent actual vehicles or exact configurations. Content based on report preparer's input is subject to the accuracy of the input provided.
Data Version: 25217. Data Updated: Apr 14, 2025 6:44:00 PM PDT.

**City of Rochester
Vehicle/Equipment Replacement Scorecard**

Vehicle # 62 Dept. Rochester Police Department

Year/ Make/ Model: 2019 Dodge Charger

Age

In Service Date: 04/2019
 Total Time (years): 6
 Points: 6

Mileage

Mileage or hours: 55,000
 Points: 11

Type of Service

Description: Police
 Points: 5

Reliability

Avg WO/Month: 4
 Road Calls: 3
 Points: 7

M&R Costs

Total Maintenance: 19700
 Annual Maintenance: 2100
 Replacement Cost: 53000
 % of Repl. Cost: 41
 Points: 3

Condition

Accidents: Yes No
 If Yes, #: 1
 Paint/Body: Minor scratches, dings, holes from add-ons
 Interior: normal wear and tear
 Drive Train: Ok
 Points: 5

Total Points: 37

0-17	Excellent	Do not replace
18-22	Good	Re-evaluate next FY for future replacement
23-27	Satisfactory	Qualified for replacement, consider replacement this FYE
28+	Poor	Strongly consider replacement this FYE

Prepared by: Lt. Harper Date: 04/23/2025

**City of Rochester
Vehicle/Equipment Replacement Guidelines**

Factor	Points	Description
Age	1	Each year of chronological age
Miles or Hours	1	Each 5,000 of usage
	1	Each 250 hours of usage
Type of Service (Heavy Equipment)	1	Standard duties as equipped
	2	Standard duties when used with attachments (sickle bar, backhoes, rear bushhogs)
	3	Multiple duties based on seasons (snow, mowing, leaf)
	4	Extreme duties in harmful atmosphere (dust, salt, water)
	5	Heavy construction work including snow removal
Type of Service (Sedans and Light Trucks)	1	Standard sedans and light pickups
	2	Standard vehicles with occasional off-road usage
	3	Any vehicle that pulls trailers, hauls heavy loads, and has continued off road usage
	4	Any vehicle involved in snow removal
	5	Police, Fire, and Rescue service vehicles
Reliability (PM work is not included)	1	In shop one time within three month time period, no major breakdowns or road calls
	2	In shop one time within three month time period, 1 breakdown/road call within 3 month time period
	3	In shop more than twice within one month time period, no major breakdowns or road calls
	4	In shop more than once within one month time period, two or more breakdowns/road calls within same time period
	5	In shop more than twice monthly, two or more breakdowns within one month time period
M&R Costs (accident repairs not included)	1	Maintenance costs are less than or equal to 20% of replacement cost
	2	Maintenance costs are 21-40% of replacement cost
	3	Maintenance costs are 41-60% of replacement cost
	4	Maintenance costs are 61-80% of replacement cost
	5	Maintenance costs are greater than or equal to 81% of replacement cost
Condition	1	No visual damage or rust and a good drive train
	2	Minor imperfections in body and paint, interior fair (no rips, tears, burns), and a good drive train
	3	Noticeable imperfections in body and paint surface, some minor rust, minor damage from add-on equipment, worn interior (one or more rips, tears, burns), and a weak or noisy drive train
	4	Previous accident damage, poor paint and body condition, rust (holes), bad interior (tears, rips, cracked dash), major damage from add-on equipment, and one drive train component bad
	5	Previous accident damage, poor paint, bad interior, drive train that is damaged or inoperative, and major damage from add-on equipment



Rochester Fire Department

TO: CITY MANAGER

FROM: FIRE CHIEF, JOHN CIESLIK

SUBJECT: FIRE INSURANCE WITHHOLDING PROGRAM

DATE: APRIL 30, 2025

For your consideration

The fire insurance Withholding Program provides municipalities with some financial protection against the cost of cleaning up a damaged structure following a fire loss. Municipalities participating may be eligible to receive a portion of a policyholder's final settlement held in a specified escrow account until the structure is repaired, replaced, or demolished, at which time the escrow funds would be released by the municipality back to the property owner. If the property owner does not repair the structure, the municipality may use the funds to repair, replace, or demolish the damaged structure.

The Department of Insurance and Financial Services (DIFS) compiles and maintains the list of participating municipalities. Updated each month and sent electronically to all property and casualty insurance companies, participating municipalities, and DIFS' list of Interested Parties. To participate, municipalities must pass a resolution and submit it to DIFS along with the Fire Insurance Withholding Program Enrollment and Notification application (FIS 0376). The effective date of participation will be 30 days after DIFS' next publication. Instructions and forms are on DIFS.'

Participation in the Withholding Program will provide the municipality within 120 days after receiving the portion of policy proceeds, the municipality may use the retained proceeds to secure, repair, or demolish the damaged or destroyed structure and clear the insured property so it complies with local code requirements.

Attorney Kragt will prepare a resolution for your consideration at an upcoming council meeting.

Thank you for your consideration.

John

John Cieslik
Fire Chief



GRETCHEN WHITMER
GOVERNOR

STATE OF MICHIGAN
DEPARTMENT OF INSURANCE AND FINANCIAL SERVICES
LANSING

ANITA G. FOX
DIRECTOR

FIRE INSURANCE WITHHOLDING PROGRAM

On the following pages are an Enrollment and Notification Form and a sample resolution for the Fire Insurance Withholding Program. You should review Sections [500.2227](#) and [500.2845](#) of the Michigan Insurance Code to determine under which section your municipality is eligible to participate in the program.

Section 2845 of the Insurance Code includes municipalities of less than 50,000 in population located in counties of less than 425,000 in population. Municipalities that meet this population criteria which have passed resolutions establishing escrow accounts will be allowed to escrow 25% of a fire insurance settlement for fire and explosion losses to real property within the boundaries of the municipality.

Section 2227 to the Insurance Code includes municipalities with a population of 50,000 or more, or those municipalities with a population less than 50,000 but in a county with a population of 425,000 or more. These municipalities will be allowed to establish escrow accounts to escrow 25% of a fire insurance settlement for losses to real property caused by fire or explosion, as well as losses caused by the perils of vandalism, malicious mischief, wind, hail, riot, or civil commotion.

Under both of the above sections of the Insurance Code, a final settlement which exceeds 49% of the insurance on the real property will serve as prima facie evidence that the municipality has cause for escrowing of the withheld amount. For residential property, the 25% settlement shall not exceed the amount adjusted annually in accordance with the consumer price index with the adjusted amount reflected in the upper right corner of the published list of participating municipalities. Both sections of the Insurance Code also establish a method for the policyholder to object to the municipality's retention of the withheld amount.

While there is no standard format for the resolution, we suggest that municipalities use the format of other resolutions adopted by their governing body. **The only legal requirement is that the resolution contain specific wording concerning the establishment of an escrow account.** The attached sample resolution contains sufficient language to that effect.

Once the resolution is passed, you need to provide the Department of Insurance and Financial Services (DIFS) with a copy, along with the enrollment form including the name and address of the person designated as the contact person for insurance companies. Your municipality and the contact person's name, address and telephone number would then be added to the list of municipalities currently participating in the program.

Updated lists are issued periodically by DIFS and distributed to licensed insurance companies. Because municipalities are prohibited from implementing the law sooner than thirty (30) days after insurers have been notified, each amended list contains an effective date for each municipality. Only **fire losses occurring after that date** are subject to the withholding provisions.

Should you have any further questions about this program, please contact DIFS toll free at 877-999-6442.

Fire Insurance Withholding Program Enrollment and Notification

Please type or print clearly

Name of Municipality	Type of Municipality (choose one) <input type="checkbox"/> City <input type="checkbox"/> Village <input type="checkbox"/> Township	Located in the Michigan County of:
Name and title of Contact Person	<p style="text-align: center;">Please return completed form to:</p> <p style="text-align: center;">Department of Insurance and Financial Services Office of Consumer Services PO Box 30220 Lansing MI 48909-7720</p>	
Contact Person complete address		
Contact Person phone number (with area code) ()		
Contact Person email address		

Municipality will be participating under the following section of the Michigan Insurance Code (choose one):

- Section 2845 - Municipalities of less than 50,000 in population located in counties of less than 425,000 in population.
- Section 2227 - Municipalities with a population of 50,000 or more, or those municipalities with a population less than 50,000 but in a county with a population of 425,000 or more.

Please enroll this municipality in the Fire Insurance Withholding Program.

Authorized signature	Date signed	Signer's name and title, typed or printed
----------------------	-------------	---

P.A. 216 and 217 of 1998 require submission of this information by municipalities that wish to enroll in the Fire Insurance Withholding Program.



Michigan Department of Insurance and Financial Services

DIFS is an equal opportunity employer/program.

Auxiliary aids, services and other reasonable accommodations are available upon request to individuals with disabilities.

Visit DIFS online at: www.michigan.gov/difs Phone DIFS toll-free at: 877-999-6442

SAMPLE RESOLUTION # _____

TOWNSHIP/CITY/VILLAGE OF _____

WHEREAS, the provisions of Act 495 of the Public Acts of 1980; as amended by Act 216 of the Public Acts of 1998, and the provisions of Act 217 of the Public Acts of 1998, provide that a portion of certain casualty losses for fire or explosion otherwise payable by insurers may be withheld in escrow by participating municipalities in order to secure repair, replacement or removal of damaged structures which violate the *Township/Village/City of* _____ health or safety standards; and

WHEREAS, the *Township/Village/City of* _____ has determined that participation in said program would protect and promote the public health, safety and welfare and wishes to be included in the list of participating municipalities published by the Commissioner of Insurance; and,

WHEREAS, the *Township/Village/City of* _____ desires to implement all procedures necessary to administer said program by designating the *Township/Village/City* official responsible for administration of the program and establish an escrow account for said purpose.

NOW, THEREFORE, IT IS HEREBY RESOLVED as follows:

1. That the *Township/Village/City of* _____ does hereby become a participating municipality in the program providing for the escrow of fire insurance as established by Act 495 of the Public Acts of 1980; as amended by Act 216 of the Public Acts of 1998, or as established by Act 217 of the Public Acts of 1998, and does declare its intention to uniformly apply the provisions of Section 2845 or Section 2227 to all property within the *Township/Village/City of* _____.
2. That the *Township/Village/City of* _____ official responsible for the administration of Section 2845 or 2227 of said Acts and any rules promulgated by the Commissioner of Financial and Insurance Services is hereby designated as follows:
3. That the *Township/Village/City of* _____ *Official* shall establish an escrow account with the _____ Bank for the purpose of receiving and holding deposits of money received from insurers pursuant to Section 2845 or 2227 of said Acts, which account shall be separately maintained from all other accounts and may be an interest bearing account.

Name, *Capacity*

Name, *Capacity*

Date _____

**RESOLUTION REGARDING PARTICIPATION IN
FIRE INSURANCE WITHHOLDING PROGRAM**

WHEREAS, the provisions of Act 495 of the Public Acts of 1980; as amended by Act 216 of the Public Acts of 1998, and the provisions of Act 217 of the Public Acts of 1998, provide that a portion of certain casualty losses for fire or explosion otherwise payable by insurers may be withheld in escrow by participating municipalities in order to secure repair, replacement or removal of damaged structures which violate that municipality's health or safety standards; and

WHEREAS, the City of Rochester has determined that participation in said program would protect and promote the public health, safety and welfare and wishes to be included in the list of participating municipalities published by the Commissioner of Insurance; and,

WHEREAS, the City of Rochester desires to implement all procedures necessary to administer said program by designating the City official responsible for administration of the program and establish an escrow account for said purpose.

NOW, THEREFORE, IT IS HEREBY RESOLVED as follows:

1. That the City of Rochester does hereby become a participating municipality in the program providing for the escrow of fire insurance as established by Act 495 of the Public Acts of 1980; as amended by Act 216 of the Public Acts of 1998, or as established by Act 217 of the Public Acts of 1998, and does declare its intention to uniformly apply the provisions of Section 2227 to all property within the City of Rochester.

2. That the City of Rochester official responsible for the administration of Section 2227 of said Acts and any rules promulgated by the Commissioner of Financial and Insurance Services is hereby designated to be the Rochester Fire Chief.

3. That the City of Rochester Official shall establish an escrow account with the _____ Bank for the purpose of receiving and holding deposits of money received from insurers pursuant to Section 2227 of said Acts, which account shall be separately maintained from all other accounts and may be an interest-bearing account.

Made and passed this ____ day of May, 2025.

CERTIFICATION

I, Lee Ann O'Connor, the duly authorized Clerk of the City of Rochester, do hereby certify that the foregoing is a true and correct copy of a Resolution adopted by the City of Rochester City Council on May ____, 2025.

Lee Ann O'Connor, City Clerk

Frequently Asked Questions

- What is the purpose of the fire insurance withholding program?

The fire insurance withholding program is designed to provide municipalities with some financial protection against the cost of cleaning up a damaged structure following a fire loss. Participating municipalities may be eligible to receive a portion of a policyholder's final settlement to be held in a specified escrow account until the structure is repaired, replaced, or demolished, at which time the escrow funds would be released by the municipality back to the property owner. If the property owner does not repair the structure, the municipality may use the funds to repair, replace, or demolish the damaged structure.

- Municipalities - How can we participate?

The Department of Insurance and Financial Services (DIFS) compiles and maintains the list of participating municipalities. The list is updated each month and is sent electronically to all property and casualty insurance companies, participating municipalities, and DIFS' list of Interested Parties. In order to participate, municipalities must pass a resolution and submit it to DIFS along with the Fire Insurance Withholding Program Enrollment and Notification application (FIS 0376). The effective date of participation will be 30 days after DIFS' next publication. Instructions and forms are on DIFS' website www.michigan.gov/DIFS.

[Fire Insurance Withholding Program Enrollment and Notification](#)

- Municipalities - Under which section should we enroll?

Enrollment in this program is based on the population of the municipality and/or the county in which it is located.

- **Section 2227** of the Michigan Insurance Code applies to any municipality that is located in:
 - Counties of 425,000 or more, regardless of the size of the municipality (currently Genesee, Kent, Macomb, Oakland, Wayne), *or*
 - Cities of 50,000 or more, regardless of the size of the county.
- **Section 2845** of the Michigan Insurance Code applies to any municipality of less than 50,000 in population located in counties of less than 425,000.
- Besides population requirements, are there any differences between Sections 2845 and 2227?

The only difference between the two Sections is that additional perils are eligible for larger municipalities:

- Section 2845 pertains to real property damage caused by *fire or explosion*.
- Section 2227 pertains to real property damage caused by *fire or explosion, as well as* losses caused by the perils of *vandalism, malicious mischief, wind, hail, riot, or civil commotion*.
- Are all losses covered by this program?
- Is a mobile home considered "real property" for purposes of this program?
- Insurance Companies - How do we calculate the escrow amount?
- Is the maximum escrow amount the total that can be in the account, or the maximum amount per claim?
- Municipalities - What do I need to do after a loss has occurred in our municipality?

The responsibility is on the insurance company to notify you. You may contact the insurance company, if known, to notify them a loss has occurred in a participating municipality and you are interested in having the eligible amount of the settlement placed in escrow.

- In the event of a loss, what are the responsibilities of the insurance company and the participating municipality?

In the event of a loss in one of the participating municipalities the following steps should occur:

- Within 15 days after agreement on a final settlement between the insured and the insurer, the **insurance company** determines whether the loss meets the guidelines of the program. *If the insured has filed with the insurer evidence of a contract to repair the property and consents to the payment of funds directly to the contractor performing the repair services, the insurer should notify the participating municipality there will not be a withholding because of repair contract. (Section 2845(13) & Section 2227(15)).*
- If the program eligibility guidelines are met, the insurer sends written notice of the withholding to the following:
 - contact person listed for the particular municipality;
 - the insured;
 - any mortgagee; and
 - the court, if any judgment was entered.

(Sections 2227(1) & 2845(1) covers the required elements of this written

notification)

- The **municipality** has **15 days** after the mailing of the notice from the insurance company to respond and request the withheld amount be paid into its escrow account (Sections 2845(1)(f) & 2227(1)(f)). A copy of the municipality's response to the insurance company must also be sent to the *insured*, any *mortgagees*, and the *court*, as applicable, advising that they have **10 days** from the mailing to object to the retention of the withheld amount (Sections 2845(2)(d) & 2227(2)(d)).
- Insurance Company - Where can I get the forms to notify the involved parties that the loss meets the eligibility criteria of the Fire Insurance Withholding Program?
- When can the money be disbursed after it has been escrowed?

The municipality must immediately forward the policy proceeds, except any interest earned while in escrow, to the insured or to the service contractor as outlined below upon reasonable proof (defined in Sections 2845(5) & 2227(5)) of one of the following:

- The damaged or destroyed structure has been repaired or replaced except to the extent that the amount withheld is needed to complete the repairs.
- The damaged or destroyed structure has been removed and completely cleared in compliance with local code requirements.

The insured may seek resolution with the municipality or seek relief in circuit court if they feel the municipality has not properly disbursed the funds. (Sections 2227(2)(d) & 2845(2)(d)).

If reasonable proof is not presented to the municipality within 120 days after receiving the portion of policy proceeds, the municipality may use the retained proceeds to secure, repair, or demolish the damaged or destroyed structure and clear the insured property so it complies with local code requirements. Any unused portion of the retained proceeds shall be returned to the insured. The municipality may extend the 120 day time period.

- Municipality - What if the insurance company failed to notify us about the escrow opportunity and paid the insured in full?

If an insurance company settles a claim without notifying a participating municipality of the loss, the municipality may file a written complaint with DIFS. The complaint should include the name of policyholder/property owner, date of loss, and name of the insurance company. You may file a complaint online by visiting www.michigan.gov/DIFScomplaints or calling 1-877-999-6442 to request a complaint form.

MAYOR NOMINATIONS

Brownfield Redevelopment Authority

THREE SEATS AVAILABLE

Christian Hauser RENEW

Cemetery Advisory Board

FIVE SEATS AVAILABLE

Susan Eaton - RENEW

City Beautiful Commission

FIVE SEATS AVAILABLE

STUDENT SEATS AVAILABLE

Sue Butala RENEW

Julia Johnson RENEW

Sandra Montes RENEW

Jeanine Offer RENEW

Laura Murphy RENEW

Natalie Sapp STUDENT

Emma Loosvelt STUDENT

Compensation Commission

NO SEATS AVAILABLE

Construction Board of Appeals

Tom Czerwinski RENEW

Downtown Development Authority

FOUR SEATS AVAILABLE

Robert Bloomingdale RENEW

Paul Haig RENEW

Roger Knapp RENEW

Historical Commission

UP TO SIX SEATS AVAILABLE

Donald Washeleski NEW

Julia Johnson NEW

OPEB Retirement Board

Citizen Seat

David Berletich RENEW

Parking Advisory Board

Citizen Seat

Jana Yezak RENEW

Planning Commission

THREE SEAT AVAILABLE

David Gassen RENEW

Richard Kendziuk RENEW

Matt Stone RENEW

Principial Shopping District

TWO SEATS AVAILABLE

Philip Munroe NEW QUALIFIED

Lynn Oates NEW QUALIFIED

David Berletich NEW NOT QUALIFIED

Rosie Rivel NEW NOT QUALIFIED

Tree Committee

ONE SEAT AVAILABLE

Jeanine Offer NEW

CITY COUNCIL NOMINATIONS

Board of Ethics

TWO SEATS AVAILABLE

Rosie Rivel NEW

Board of Review

NO SEATS AVAILABLE

Community Media Network

ONE SEAT AVAILABLE

NONE

Historic District Commission

ALL SEVEN SEATS AVAILABLE

David Gassen RENEW

Julia Johnson NEW

Library Liaison

NO SEAT AVAILABLE

Older Persons' Commission

NO SEAT AVAILABLE

Paint Creek Trailway Commission

ALTERNATE CITIZEN MEMBER

David Becker RENEW

Zoning Board of Appeals

THREE REGULAR SEATS AVAILABLE

David Gassen RENEW

Cody Smith RENEW

ONE ALTERNATE SEAT AVAILABLE

Jay Huh NEW



City of Rochester

400 Sixth Street
Rochester, MI 48307
P: (248) 651-9061
F: (248) 651-2624
www.rochestermi.org

PRINCIPAL SHOPPING DISTRICT BOARD MEETING AGENDA

*Members: Patti Eisenbraun, Paul Haig, Lonna Harlow,
Debbie Jones, Jill Lutz & Karen Malsbury*

Downtown Collaboration Studio, 431 S. Main	May 7, 2025	5:30 pm
---	-------------	---------

1. Call to Order
2. Roll Call
3. Approval of Meeting Minutes –
 - a. Regular Meeting Minutes – April 2, 2025
 - b. Special Meeting Minutes – April 23, 2025
4. General Business
 - a. Request for Recommendation – Sidewalk Sales
 - b. Request for Recommendation – Dancin’ in the Street
 - c. Formal Adoption of PSD FYE 26 Budget
 - d. Main Street Oakland County Main Event
5. Reports
 - a. PSD Financial Report
 - b. Events & Marketing Update
 - c. Executive Director Report
6. Miscellaneous
7. Adjourn



City of Rochester

400 Sixth Street
Rochester, MI 48307
P: (248) 733-3700
F: (248) 733-3170
www.rochestermi.org

PLANNING COMMISSION REGULAR MEETING AGENDA

Chair David Gassen
Vice Chair & Council Member Christian Hauser
Mayor Nancy Salvia
Members: Daniel Bachmann, Jessica Clauser, David Hardin,
Richard Kendziuk, Laura Murphy & Matthew Stone

See Attached Document for Virtual Meeting Instructions

400 Sixth Street	May 5, 2025	7:00 PM
-------------------------	--------------------	----------------

1. Call to Order and Roll Call
2. Pledge of Allegiance
3. Public Comment
4. Approval of the Minutes
 - A. Consideration of the Minutes of the Regular Meeting of April 7, 2025.
5. Public Hearings
 - A. Notice of Public Hearing: 203 E. University – Request for Special Exception for outdoor dining and Payment in Lieu of Parking requirements.
6. Considerations:
 - A. Consideration of 406 S. Main – Request to Set Public Hearing for Site Plan Approval, Facade Change and Payment in Lieu of Parking requirements.
7. Miscellaneous
8. Public Comment
9. Adjourn

NOTE: Anyone planning to attend the meeting who has need of special assistance under the Americans with Disabilities Act (ADA) is asked to contact the City Clerk's Office at 248-733-3700 forty-eight (48) hours prior to the meeting. Staff will be pleased to make the necessary

arrangements to provide necessary reasonable accommodations, including auxiliary aids and services, such as signers for the hearing impaired and audiotapes of printed materials being considered at the meeting.

May 9, 2025

Nik Banda, City Manager
City of Rochester
400 Sixth Street
Rochester, Michigan 48178

Re: *Request for Closed Session for City Council on May 12, 2025 to consider Attorney/Client Privileged Opinion Letter*

Dear Mr. Banda:

I am requesting that a closed session be scheduled for May 12, 2025 for City Council to consider an Attorney/Client Privileged Opinion Letter pursuant to Sec. 8(h) of the Open Meetings Act, MCL 15.268(h).

Should you have any questions, please do not hesitate to contact me.

Very truly yours,

/s/ Jeffrey Kragt

Jeffrey S. Kragt

C: Holly Meyers
Megan Frazho