

SPECIAL MEETING NOTICE

ALISO VIEJO CITY COUNCIL
WEDNESDAY, APRIL 20, 2022
6:00 PM STUDY SESSION

City Hall
Council Chambers
12 Journey
Aliso Viejo, CA



NOTICE IS HEREBY GIVEN that a Special Meeting of the City Council of the City of Aliso Viejo will take place on the date and time listed above. The business to be transacted at the special meeting will be as listed below.

SPECIAL NOTICE REGARDING COVID-19

On March 4, 2020, Governor Newsom proclaimed a State of Emergency in California as a result of the threat of COVID-19. On September 16, 2021, Assembly Bill 361 (AB 361) was signed by Governor Newsom, to allow for the City Council to attend City Council meetings telephonically and for the public to participate in the City Council meeting by electronic means.

Given the health risks associated with COVID-19, state and local officials are recommending measures to promote social distancing; therefore, the City of Aliso Viejo will not have the Council Chambers open to the public for this meeting. Members of the public may access the meeting live using any of the following sources:

- Cox Communications Channel 851
- AT&T U-Verse Channel 99
- Online at www.avcity.org
- Online at <https://attendee.gotowebinar.com/register/5063210786369783055>

Public comments may be submitted by calling (949) 425-2509 to leave a recorded message by 4:00 pm on the day of the meeting or via email to Community-Input@avcity.org. Alternatively, public comments may be submitted by logging onto the meeting through this link and using the "Raise Hand" feature: <https://attendee.gotowebinar.com/register/5063210786369783055>. Comments are limited to three minutes each.

It is the City's intention to comply with the Americans with Disabilities Act (ADA). If you need special assistance to participate in the meeting, the City will make reasonable arrangements to ensure accessibility and/or accommodations. [28 CFR 35.102-35.104 ADA Title II] Please contact the City Clerk's Office at (949) 425-2505 at least 48 hours prior to the meeting.

Supplemental documents relating to specific agenda items, including communications received after agenda delivery, are presented at the time of the meeting. Supplemental documents are also available for review by request. For more information, please contact the City Clerk's Office at (949) 425-2505.

**PLEASE SILENCE ALL CELL PHONES AND OTHER
ELECTRONIC EQUIPMENT WHILE CITY COUNCIL IS IN SESSION**

CALL TO ORDER: CONVENE SPECIAL MEETING

PUBLIC COMMENTS:

STUDY SESSION:

BICYCLE TRACKS OVERVIEW
[PowerPoint Presentation](#)

ADJOURNMENT:

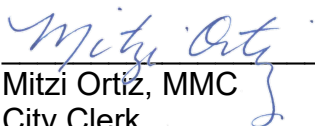

Mitzi Ortiz, MMC
City Clerk

City of Aliso Viejo Bicycle Tracks Presentation

Carlos A. Ortiz, PE,TE (CA), PTOE
Chief Operating Officer /
Consultant Project Manager
ADVANTEC Consulting Engineers, Inc.

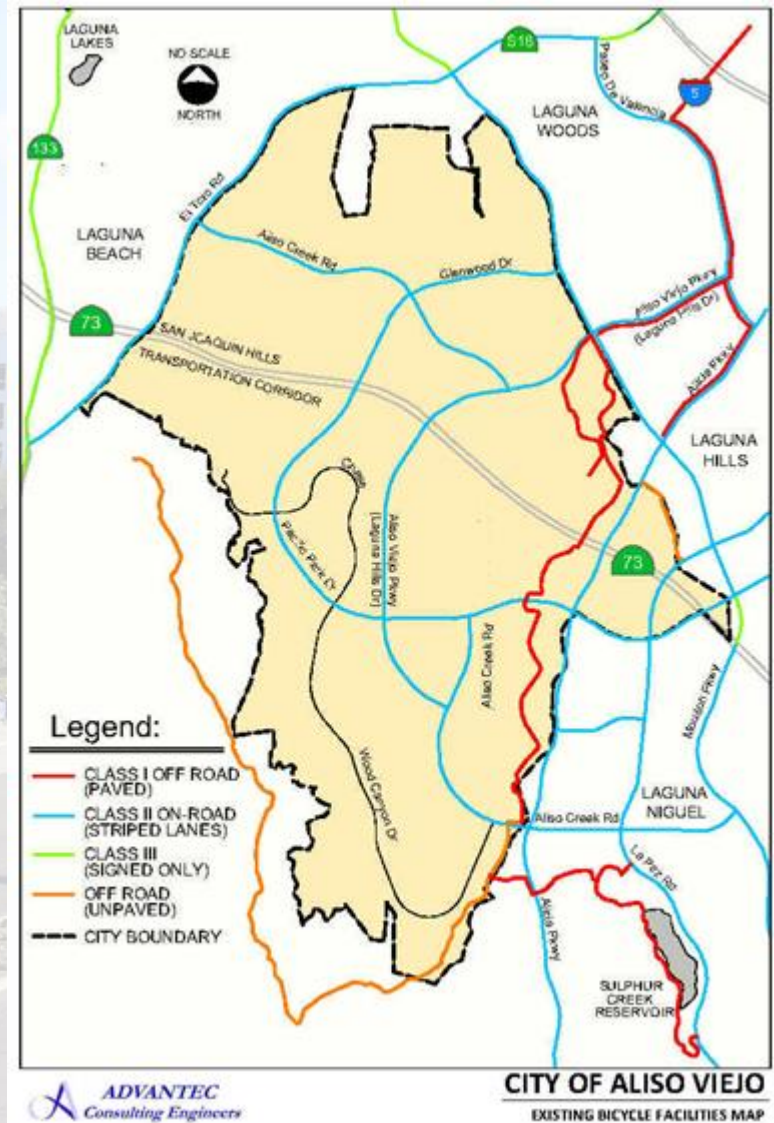

April 20, 2022

Bicycle Facilities | *Class I*

- Offsite
- Shared with Pedestrians and NEVs

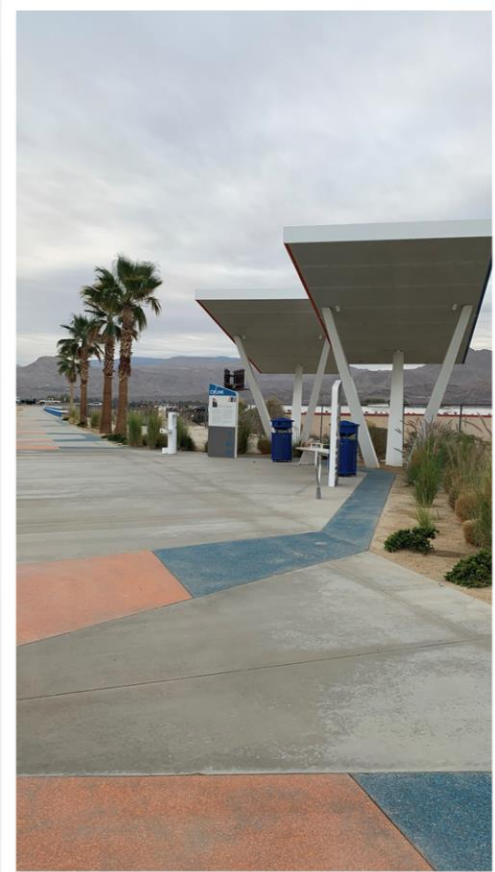

Bicycle Facilities | *Class II*

- Within Roadway Segments
- Striped Bicycle Facility (Typically 2 – 8 ft lane)



Bicycle Facilities | *Class II*



Bicycle Facilities | *Class III*

- Within Roadway Segments
- Bike Route
- Shared with Vehicles
- Sharrows

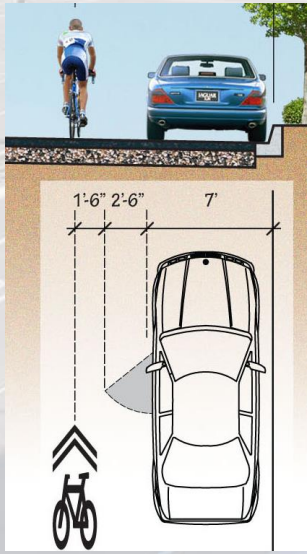
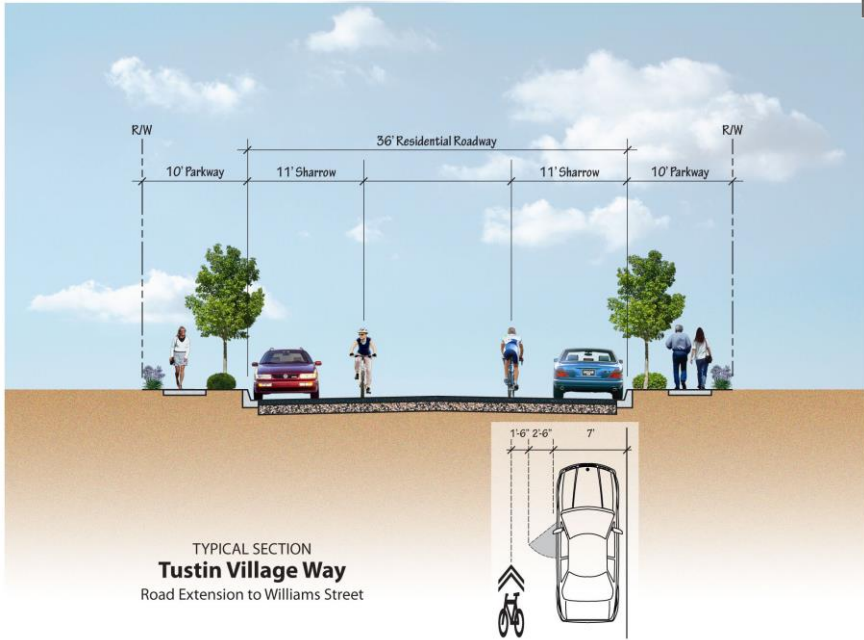

Bicycle Facilities | *Class IV (Cycle Tracks)*

- Within Roadway Segments
- 2-6 Ft Separate Buffer Area (with and w/o landscaping)
- One-Way or Two-Way Traffic
- Pedestrians/Bicyclists/NEV
- Typically 8-20 ft Lane and Shoulder
- Reduced Vehicle Lanes and/or Lane Widths
- Utility Relocation
- Drainage Impacts
- Traffic Signal Modifications
- Roadway Lighting Modifications
- Slope Maintenance Access
- Street Sweeping



Bicycle Facilities | *Class IV (Cycle Tracks)*

- Typical Along Collector and Residential Roads
- Near Beach Communities
- Grid Roadway System
- Lower Speed Roadways
- Evaluate On-Street Parking
- Evaluate Driveways
- Evaluate Ridership
- Perform Line-Of-Sight Analysis
- Evaluate Maintenance & Cost



Bicycle Facilities | *Class IV (Cycle Tracks)*

- **Connectivity to Other Bicycle Facilities**
- **Connectivity to Different Land Uses**
- **Connectivity to Multi-Modal Facilities**
- **Cannot be Located Within Caltrans Right-of-Way**



City of Aliso Viejo: Cycle Track/Class IV Bicycle Facilities Assessment and Study – Phase I (Initial Phase)

- Project Management
- Data Collection and Field Work
- Evaluate City's Bicycle Facilities and Gaps
- Evaluate City's Roadway Classification and Posted Speeds
- Bicycle Counts (if needed)
- Evaluate a One-Way or Two-Way Cycle Track
- Initial Recommendation of Selected Corridors to Further Evaluate Cycle Tracks/Class IV Applications in the City
- Community Outreach Meetings
- Planning/City Council Meetings



City of Aliso Viejo: Cycle Track/Class IV Bicycle Facilities

Assessment and Study – Phase II (Intermediate Phase)

- Project Management
- Conceptual Design of Bicycle Facilities
- Review and Evaluate of Existing Geometrics (Vertical and Horizontal)
- Review and Evaluate Existing Utilities near the Curb/Gutter
- Review and Evaluate Line-of-Sight at Driveways/Intersections
- Evaluate Vehicle Turning Analysis
- Evaluate Traffic Signal Upgrades
- Provide and Engineer's Cost Analysis for selected Corridor(s)
- Evaluate Pilot Project and Location
- Community Outreach Meetings
- Planning/City Council Meetings

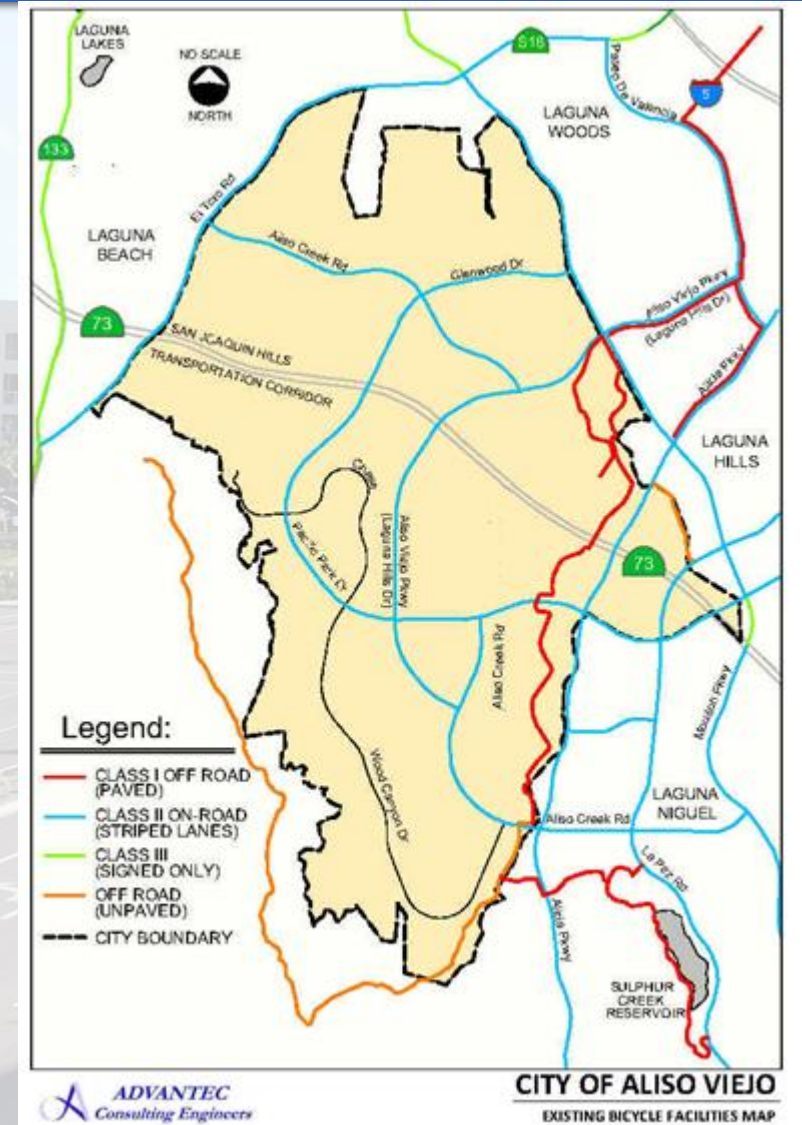

City of Aliso Viejo: Cycle Track/Class IV Bicycle Facilities Assessment and Study – Phase II (Intermediate Phase)

- Review and Evaluate Line-of-Sight at Driveways/Intersections

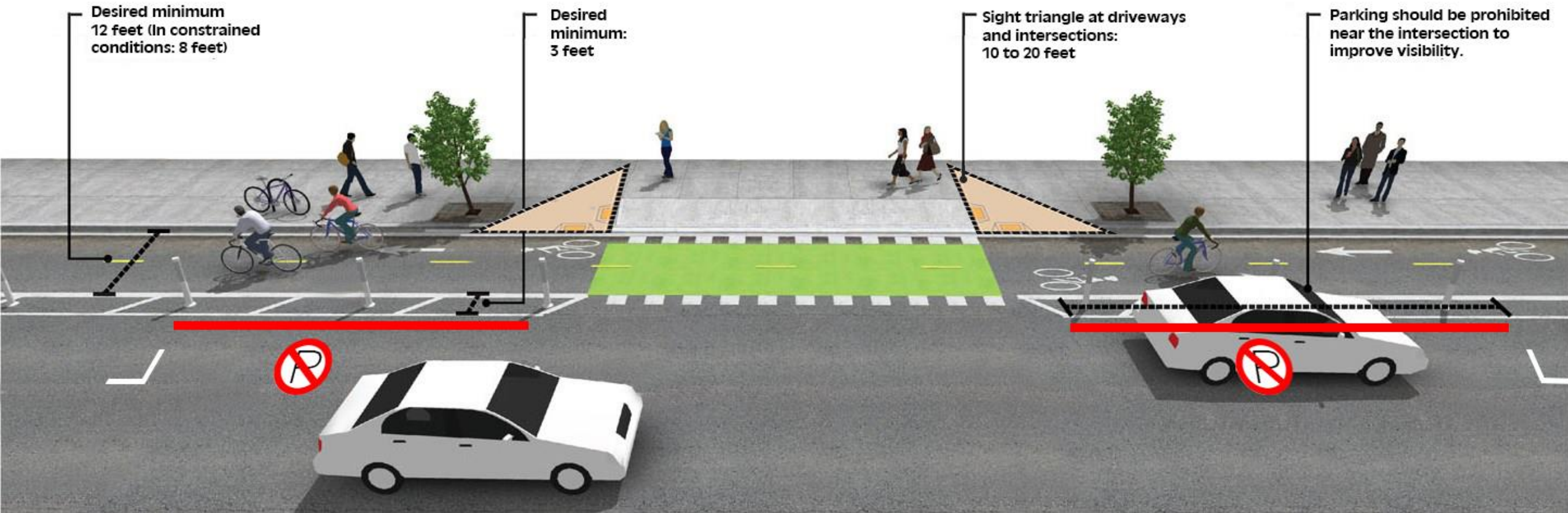

City of Aliso Viejo: Cycle Track/Class IV Bicycle Facilities Assessment and Study – Phase III (Final Phase)

- **Project Management**
- **Evaluate Drainage Facilities with Recommended Design**
- **Evaluate Median Treatments if a Raised Median is Recommended**
- **Evaluate Maintenance & Cost**
- **Benefit-Cost Analysis**
- **Final Recommendations**
- **Evaluate Funding Opportunities**
- **Community Outreach Meetings**
- **Planning/City Council Meetings**
- **Develop City's Standards for Bicycle Facilities**

City of Aliso Viejo: Cycle Track/Class IV Bicycle Facilities Assessment and Study – Phase III (Final Phase)

- **Buffer Treatment Best Practices**

Armadillo Raised Markers



PCC Curb



Alternative Solutions

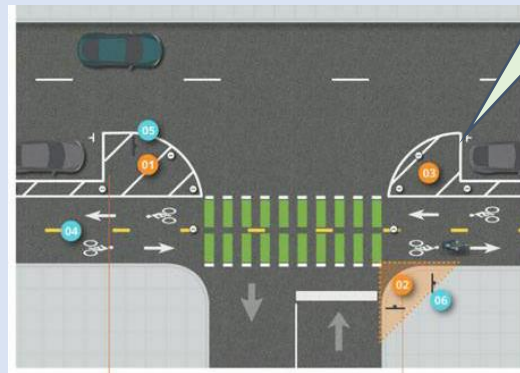

Striping Treatment

Stamped Pavement Treatment



City of Aliso Viejo: Cycle Track/Class IV Bicycle Facilities Assessment and Study – Phase III (Final Phase)

- **Buffer Treatment Best Practices**



Landscaped
Areas

Drainage Inlet



Drainage Openings

City of Aliso Viejo: Cycle Track/Class IV Bicycle Facilities Assessment and Study – Phase III (Final Phase)

- **Cycle Tracks Treatment Best Practices**



City of Aliso Viejo: Cycle Track/Class IV Bicycle Facilities Assessment and Study – Phase III (Final Phase)

- **Buffer Intersection Treatment Best Practices**

